

Simmerring BADUO

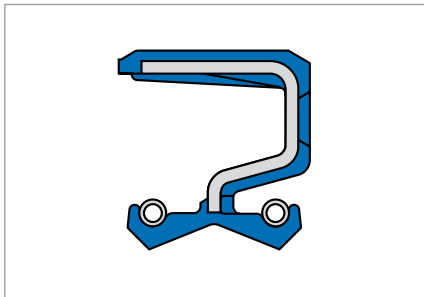

Fig. 1 Simmerring BADUO NBR

Material

Acrylonitrile-butadiene rubber

Code	72 NBR 902
Hardness	72 Shore A
metal insert	Unalloyed steel DIN EN 10027-1*
Spring	Spring steel DIN EN 10270-1*

* Individual dimensions have two metal inserts or one metal insert in the matched form.
75 FKM 585 and 75 FKM 595 on enquiry.

Operating conditions

Media	Mineral oils, synthetic oils*, greases
T	-40 ... +100 °C short term up to... +120 °C
v	to 5 m/s
p	to 0,05 MPa/0,5 bar

* With synthetic oils (polyalkylene glycols/polyalphaolefins, → Technical Manual synthetic lubricants)
it is to be noted that the maximum operating temperature of 80 °C must not be exceeded.

Max. permissible values depend on the other operating conditions.

Product description

- Outer casing: elastomer
- Two spring-loaded sealing lips.

Product advantages

- Sealing for the separation of two media
- Small housing
- Two spring-loaded sealing lips (one spring-loaded dust lip against moderate to medium dust and dirt ingress)
- Reliable sealing of the housing bore, even with increased roughness of the bore, thermal expansion and split housings.

Application

- Machine tools
- Power take-off gears in agricultural and construction machinery transmissions and axles.

Fitting & installation

Shaft

Tolerance	ISO h 11
Runout	IT 8
Roughness	$R_a = 0,2 \dots 0,8 \mu\text{m}$
	$R_z = 1,0 \dots 5,0 \mu\text{m}$
	$R_{max} = <6,3 \mu\text{m}$
Hardness	45 ... 60 HRC
Finish	No lead; preferably plunge ground

Housing bore

Tolerance	ISO H8
Roughness	$R_z = 10 \dots 25 \mu\text{m}$

Careful fitting according to DIN 3760 is a prerequisite for the correct function of the seal → Technical Manual.

Range of dimensions for shafts-Ø d₁

Simmerring BADUO	25 ... 150 mm
------------------	---------------

Article list

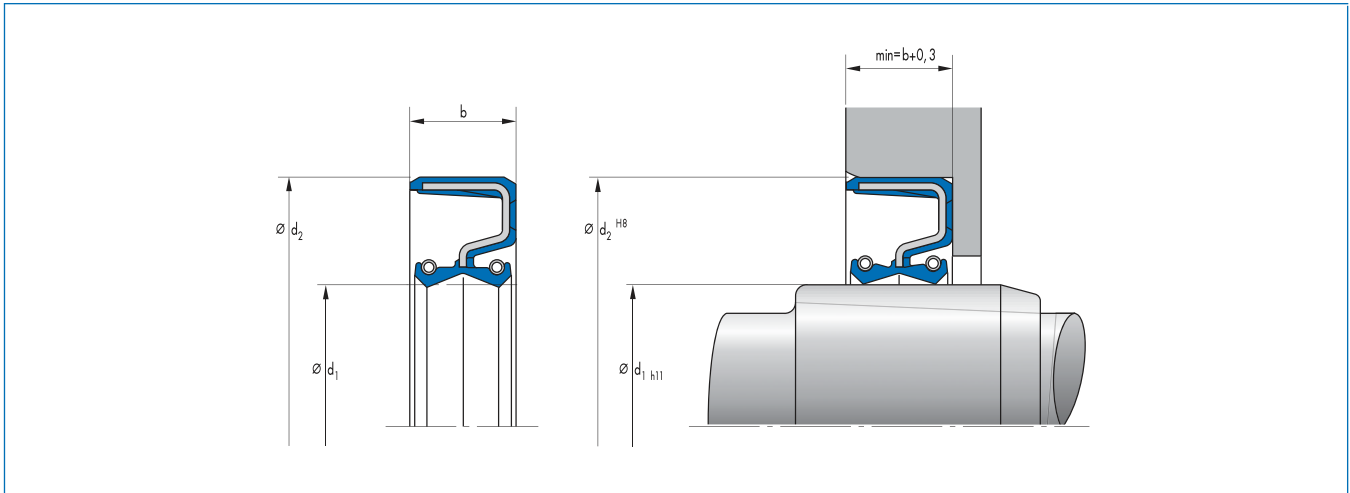

d_1	d_2	b	DIN 3761	Outer surface	Pressure	Material	Article No.	
20	40	14	A	smooth	0,05	72 NBR 902	7147	○
25	35	7	A	smooth	0,05	72 NBR 902	3473	○
25	45	14	A	smooth	0,05	72 NBR 902	7453	○
30	45	8,5	A	smooth	0,05	72 NBR 902	3475	○
30	62	14	A	smooth	0,05	72 NBR 902	7786	○
35	62	14	A	smooth	0,05	72 NBR 902	8058	○
35	62	14	A	smooth	0,05	75 FKM 595	338716	○
40	65	20	A	smooth	0,05	72 NBR 902	8300	○
45	62	14	A	smooth	0,05	72 NBR 902	32896	○
55	75	15	A	smooth	0,05	72 NBR 902	8817	○
75	90	15	A	smooth	0,05	72 NBR 902	9162	○
110	150	18	A	smooth	0,05	72 NBR 902	9389	○
118	140	16	A	smooth	0,05	72 NBR 902	9406	○
120	150	16	A	smooth	0,05	72 NBR 902	370744	○
540	585	30	A	smooth	0,05	72 NBR 902	319550	○

● Available from stock ○ On request: Tool is available, delivery at short notice

Simmerring BAHD

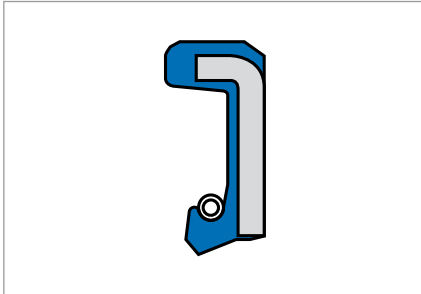

Fig. 1 Simmerring BAHD

Material

Code	90 NBR 129208
	88 FKM 107725

Operating conditions

T	-40 ... +100 °C (NBR)
	-25 ... +160 °C (FKM)
v_{U max}	2 m/s
P_{max}	0,15 MPa/150 bar

Max. permissible values depend on the other operating conditions.

Product description

High pressure seal.
Type BA with short, very stable sealing lip for high pressures, oil groove on the air side of the sealing lip.

Product advantages

- For use against high pressures
- Extremely stable sealing lip
- Low wear
- Long service life.

Application

All hydrostatic drives with low rotational speed.

Simmerring Premium Pressure Seal (PPS)

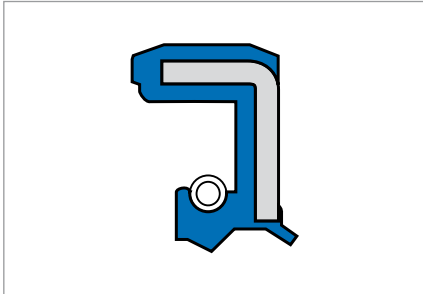

Fig. 1 Simmerring Premium Pressure Seal (PPS)

Product description

Type BA with patented sealing lip pressure loads.

Product advantages

- Low wear
- Low friction
- Long service life.

Application

Hydrostatic drives, retarders.

Material

Code	72 NBR 902
	75 FKM 595

Further information about elastomers on enquiry.

Operating conditions

T	-40 ... +100 °C (NBR)
	-25 ... +160 °C (FKM)
v_{U max}	15 m/s
P_{max}	0,1 MPa/10 bar

Max. permissible values depend on the other operating conditions.

In comparison to the standard BABSL design, up to 25% higher loads are permissible depending on the operating conditions.

Simmerring Radiamatic® EWDR made of PTFE

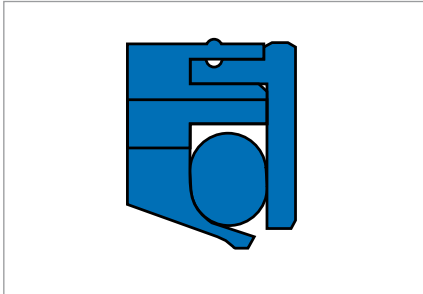

Fig.1 Simmerring Radiamatic® EWDR made of PTFE

Product description

Pressure-relieved Simmerring with a pressure ring made of PTFE compound, a stainless steel clamping ring and an O-ring (FKM) as a secondary seal.

Product advantages

Secure with simultaneous high pressure and high speed

- Low losses
- Low leak rate
- Easy fitting
- The shaft must not be machined on maintenance or seal replacement.

Application

- Primary seal in pumps and compressors
- Rotary joints for coolants and hydraulic fluid as well as gases
- Safety seal in addition to floating ring seals.

Material

PTFE carbon (standard quality)	Approved to KTW (drinking water) and BAM (oxygen)
PTFE Ekonol	Positively assessed by TNO, Nutrition and Food Research Laboratory (NL), for foodstuffs
Clamping ring	Usage of stainless steels

Operating conditions

Media	Resistance per FKM
Temperature	-20 ... +200 °C
Circumferential speed	max. 20 m/s for 1 MPa
Pressure difference	max. 3 MPa ... 0,2 MPa
For vacuum or pressure reversal	up to 0,2 MPa, housing closed

Surface, hardness

Peak-to-valley heights	R _a	R _t
Housing	<1,8 µm	<10,0 µm
Shaft, ground with no lead	0,1 ... 0,2 µm	0,5 ... 1,0 µm
Hardness of the contact area*	50-65 HRC, >0,5 mm depth of hardening	

* depending on material

Design notes

Tolerances

Shaft	Radial shaft deflection, max.*
h11	±0,05 mm

* depending on increase in rotational speed, the radial shaft deflection may need to be more tightly limited. Please enquire.

p · v Diagram

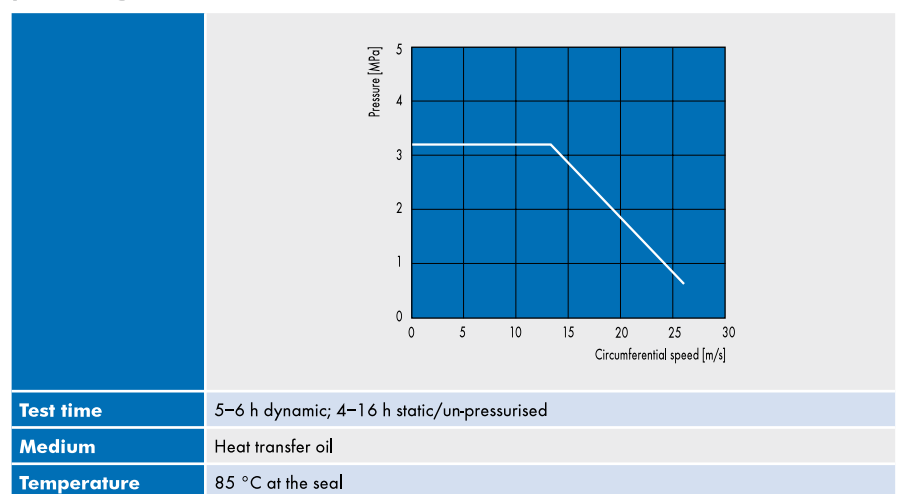

Fitting & installation

Fitting sequence: press Simmerring Radiamatic EWDR into housing; insert shaft.

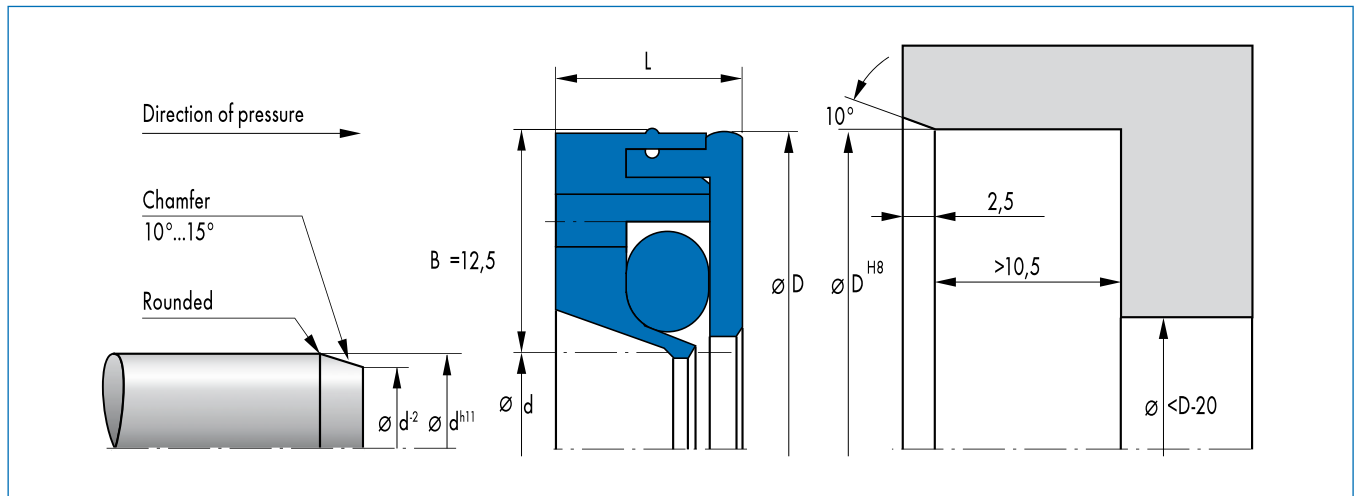

Ø d	Ø D	L
20	45	10,5
25	50	10,5
28	53	10,5
30	55	10,5
35	60	10,5
40	65	10,5
45	70	10,5
50	75	10,5
55	80	10,5
60	85	10,5
65	90	10,5
70	95	10,5
75	100	10,5
80	105	10,5
90	115	10,5
100	125	10,5

Other dimensions on enquiry.

Simmerring Energy Saving Seal (ESS)

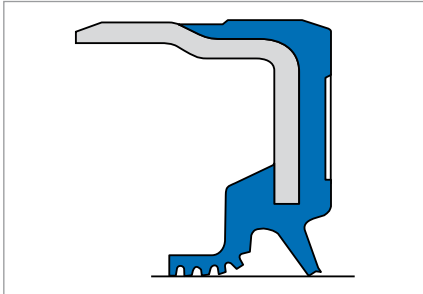

Fig. 1 Simmerring Energy Saving Seal (ESS)

Product description

Springless Simmerring with return pumping helix.

Product advantages

- Very low friction
- Reduction of dissipation loss and production of heat
- Low wear
- Long service life.

Application

Engines, automobile and industrial gearboxes.

Material

Code	75 NBR 106200
	75 FKM 595
	70 ACM 121433

Operating conditions

For one direction of rotation of the shaft:

T	-40 ... +100 °C (NBR)
	-30 ... +150 °C (ACM)
	-25 ... +160 °C (FKM)
v_{U max}	30 m/s
P_{max}	0,02 MPa/0,2 bar

Max. permissible values depend on the other operating conditions.

Simmerring High Low Pressure Seal (HLPS)

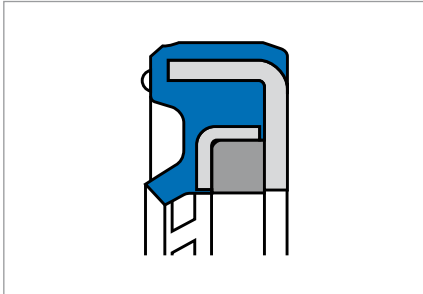

Fig. 1 Simmerring High Low Pressure Seal (HLPS)

Material

Code	HNBR
Back-up ring	PTFE

Operating conditions

T	-40 ... +120 °C
v_{U max}	2 m/s
P_{max}	0,22 MPa/220 bar

Max. permissible values depend on the other operating conditions.

Product description

Special type BA with springless sealing lip and integrated special back-up ring.

Product advantages

- Reliably seals under the most extreme pressures
- Long service life
- Low wear
- Compact design.

Application

Hydrostatic drives subject to very high stress.

Simmerring Radiamatic® HTS II made of PTFE

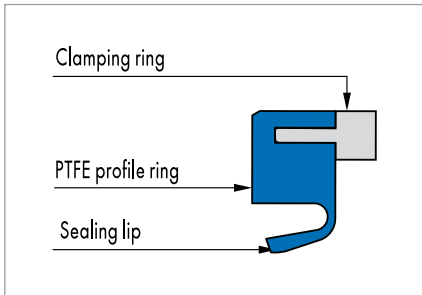

Fig. 1 Simmerring Radiamatic® HTS II made of PTFE

Product description

Simmerring for open housings. Significantly reduced lip pre-load compared to conventional geometries with high level of protection against leaks.

Product advantages

- Low friction torque
- Good dry running properties
- Low clearance volume
- Easy to clean
- Type can be easily matched to housing.

Application

Rotary pumps, agitators, gearboxes, fans, compressors, mixers, machine tools.

Material

PTFE carbon (standard quality)	Approved to KTW (drinking water) and BAM (oxygen)
PTFE Ekonol	Positively assessed by TNO, Nutrition and Food Research Laboratory (NL), for foodstuffs
Clamping ring	Usage of stainless steels

Operating conditions

Temperature range	-20 ... +200 °C
Circumferential speed	18 m/s for 0,15 MPa
Abs. pressure	0,6 MPa

When used un-pressurised, significantly higher circumferential speeds are possible. Special versions are available for alternating operation in pressure/vacuum.

Surface, hardness

Peak-to-valley heights	R_a	R_t
Housing	<1,8 µm	≤10,0 µm
Shaft, ground with no lead	0,1 ... 0,2 µm	0,5 ... 1,0 µm
Hardness of the contact area	50 ... 65 HRC, >0,5 mm depth of hardening	

The surface hardness of the running surface must be approx. 30 HRC.

Percentage contact area M_v > 50% up to max. 90% at cutting depth $c = Rz/2$ and reference line $C_{ref} = 0\%$.

Design notes

Please observe our general design notes in → Technical Manual.

Tolerances

Housing bore	Shaft	Radial shaft deflection, max.*
H8	h11	±0,05 mm

* depending on increase in rotational speed, the radial shaft deflection may need to be more tightly limited. Please enquire.

p · v Diagram

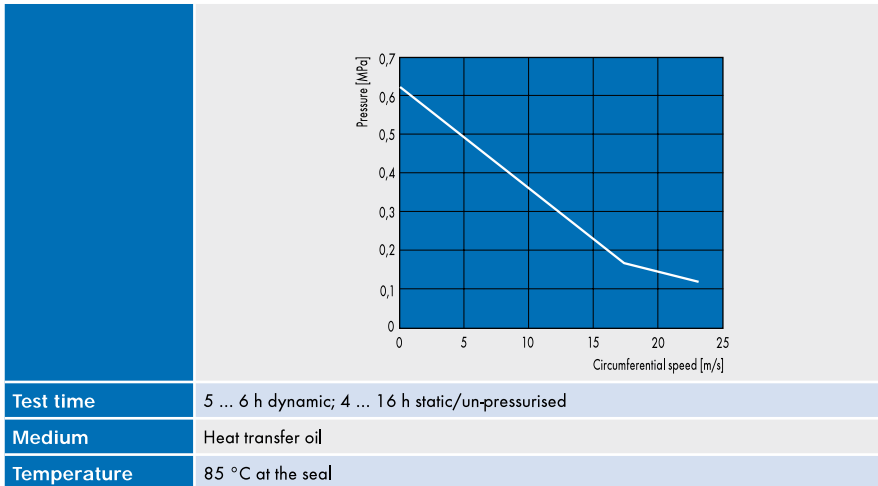

Fitting & installation

Careful fitting is a prerequisite for the correct function of the seal.
→ Technical Manual.

Article list

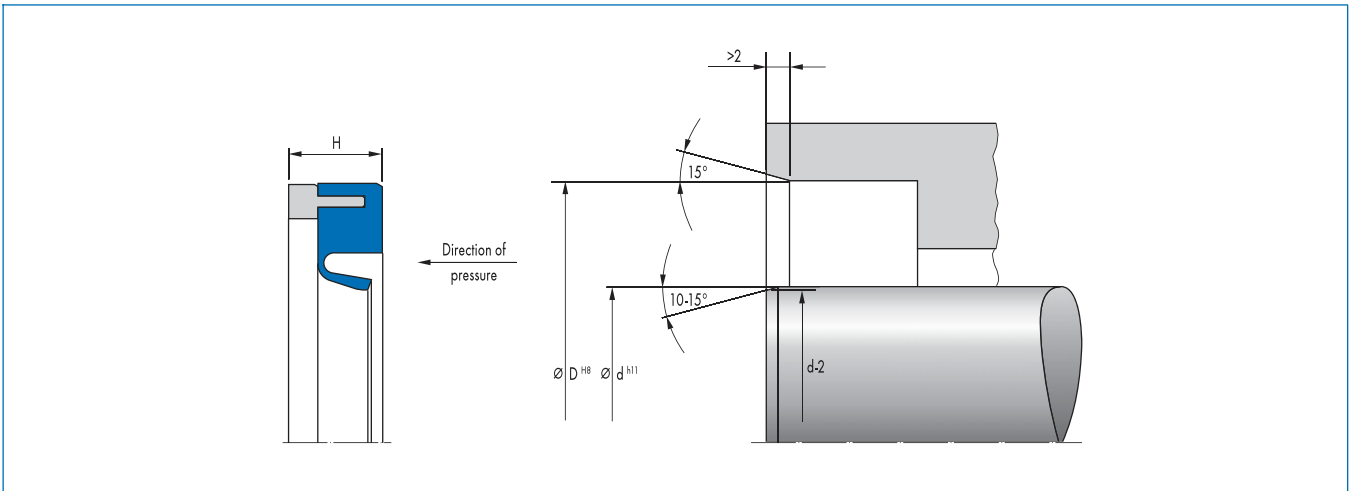

Width	D	L	Material	Article No.	
10	22	7	PTFE K212	24339323	○
12	22	7	PTFE K212	24339324	○
12	28	7	PTFE K212	24339325	○
15	30	7	PTFE K212	24339326	○
15	35	7	PTFE K212	24339327	○
17	35	7	PTFE K212	24339328	○
18	30	7	PTFE K212	24339329	○
20	30	7	PTFE K212	24339330	○
20	32	7	PTFE K212	24339331	○
20	35	7	PTFE K212	24339332	○
20	40	7	PTFE K212	24339333	○
22	40	7	PTFE K212	24339334	○
25	40	7	PTFE K212	24339335	○
25	42	7	PTFE K212	24339336	○
28	40	7	PTFE K212	24339337	○
28	47	7	PTFE K212	24339338	○
30	40	7	PTFE K212	24339339	○
30	42	7	PTFE K212	24339340	○
30	47	7	PTFE K212	24339341	○
30	52	7	PTFE K212	24339342	○
32	47	7	PTFE K212	24339343	○
35	47	7	PTFE K212	24339344	○
40	52	7	PTFE K212	24339345	○
42	62	8	PTFE K212	24339346	○
45	62	8	PTFE K212	24339347	○
45	65	8	PTFE K212	24339348	○
50	68	8	PTFE K212	24339349	○
50	72	8	PTFE K212	24339350	○
55	70	8	PTFE K212	24339351	○
55	80	8	PTFE K212	24339352	○
60	75	8	PTFE K212	24339353	○
60	80	8	PTFE K212	24339354	○
60	85	8	PTFE K212	24339355	○
65	85	10	PTFE K212	24339356	○
65	90	10	PTFE K212	24339357	○

● Available from stock ○ On request: Tool is available, delivery at short notice

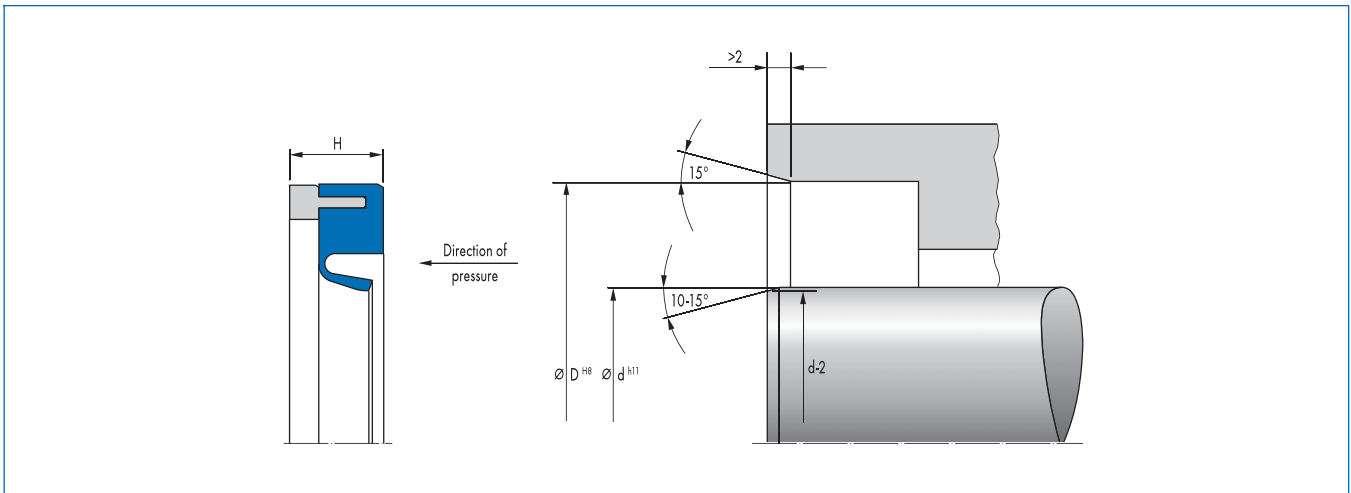

Width	D	L	Material	Article No.	
70	90	10	PTFE K212	24339358	○
70	100	10	PTFE K212	24339359	○
75	95	10	PTFE K212	24339360	○
75	100	10	PTFE K212	24339361	○
80	100	10	PTFE K212	24339362	○
80	110	10	PTFE K212	24339363	○
85	100	12	PTFE K212	24339364	○
90	120	12	PTFE K212	24339365	○
95	120	12	PTFE K212	24339366	○
100	120	12	PTFE K212	24339367	○
100	130	12	PTFE K212	24339368	○
110	130	12	PTFE K212	24339369	○
125	150	12	PTFE K212	24339370	○

● Available from stock ○ On request: Tool is available, delivery at short notice

Simmerring Poly Tech Seal (PTS)

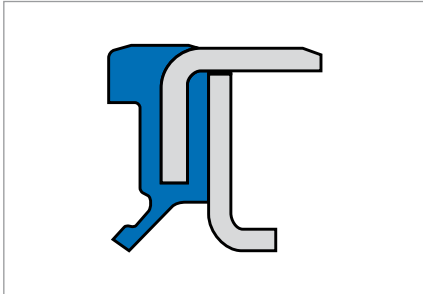

Fig. 1 Simmerring Poly Tech Seal (PTS)

Material

Code	NBR, FKM, HNBR, ACM PTFE: diverse special compounds depending on application
-------------	---

Operating conditions

T	-60 ... +200 °C (depending on combination of materials)
v_{U max}	30 m/s
P_{max}	10, MPa/10 bar

Max. permissible values depend on the other operating conditions.

Product description

Type BA or BD with vulcanised PTFE sealing lip with and without return pumping helix, with optional elastomer or fleece dust lip.

Product advantages

- Good static tightness through elastomer joining
- Low friction
- Low wear even during dry running
- High temperature resistance
- Pressure resistance
- With return pumping helix for reliable sealing even with special fluids.

Application

Hydrostatic drives, compressors, food-stuffs and chemicals industry, household appliances.

Simmerring Radiamatic® R 35

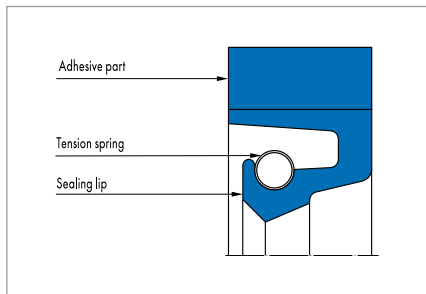

Fig. 1 Simmerring Radiamatic® R 35

Product description

Simmerring with a fabric reinforced static part that is securely joined to the elastomer sealing lip. The sealing lip is also pre-loaded with a garter spring.

Product advantages

Sealing ring is used, in case of adequate lubrication by the medium to be sealed, preferably where shafts pass through walls in mills and large gearboxes in heavy machinery manufacture.

- Particularly robust static part
- Lasting radial contact pressure
- Highly wear-resistant.

Application

Mills, ship building, steel hydraulics engineering, wind power plants.

Material

Sealing lip	Static part	Tension spring
80 NBR B241	Impregnated cotton fabric B4 B248	ST 1.4571
80 FKM K670	Impregnated aramide fabric C2 K670	ST 1.4571
75 HNBR U467	Impregnated aramide fabric C2 U464	ST 1.4571

Operating conditions

Material	80 NBR B241	80 FKM K670	75 HNBR U467
	Temperature range in °C		
Mineral oils	-30 ... +100	-10 ... +180	-20 ... +140
Water	+5 ... +100	+5 ... +80	+5 ... +100
Lubricating greases	-30 ... +100	-10 ... +180	-20 ... +140
Rolling oil emulsion	on enquiry		
Pressure p in MPa	0,05		
Running speed v in m/s	20	25	25

Other media on enquiry. Application parameters are recommended values, do not utilise all parameters simultaneously.

Surface quality

Peak-to-valley heights	R _a	R _{max}
Running surface	≤0,6 µm	≤2,5 µm
Housing	≤4 µm	≤15 µm

The contact area is machined by plunge grinding, i.e. without feed. The surface hardness must be approx. 60 HRC (depth of hardening min. 0,5 mm). With increasing circumferential speed the contact area should be manufactured with increasing peak-to-valley heights R_a. The surface should not be too smooth so that an adequate film of lubricant can form. Recommended value: R_{a min} = 0,1 µm. Percentage contact area M_r >50% to max. 90% at cutting depth c = Rz/2 and reference line C ref = 0%. Abrasive surfaces, ridges, scratches and blow-holes are to be avoided.

Design notes

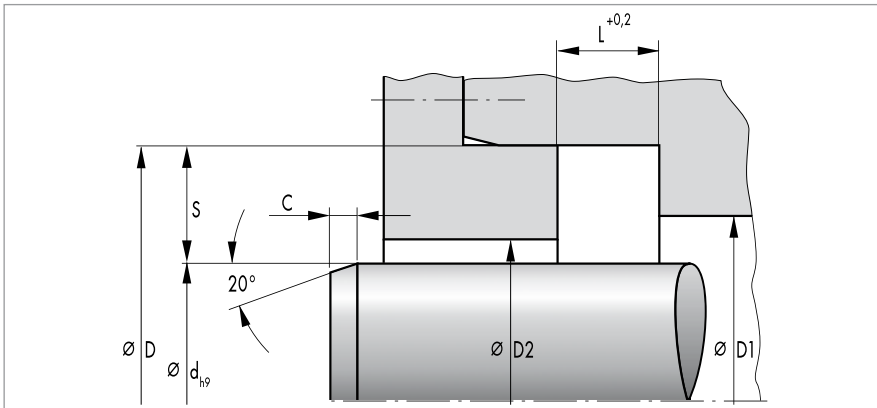

Fig. 2

Please observe our general design notes in → Technical Manual.

Lead-in chamfers

See dimension "C" in the article list.

Tolerances

D	Tolerance
<500	H8
>500	+0,0004 x D

Overall eccentricity

The permissible overall eccentricity (static and dynamic eccentricity) between shaft and housing is dependent on the seal profile and circumferential speed. If necessary, we will provide recommended values.

Housing recommendations for new designs

d	S (Profile)	L
>100	20	16
>250	22	20
<450	25	22
>750	32	25

Fitting & installation

For Simmerring Radiamatic R 35 an axially accessible housing is necessary, as the rings must have low inclination. The Radiamatic R 35 rings are supplied with oversize seal width. For reliable function the Radiamatic R rings must be axially compressed to the dimension "L". An open housing with cover plate and tightening screws is necessary. Specific deformation forces are necessary for the compression. The cover plate and the tightening screws are to be designed appropriately. Please request recommended values.

Article list

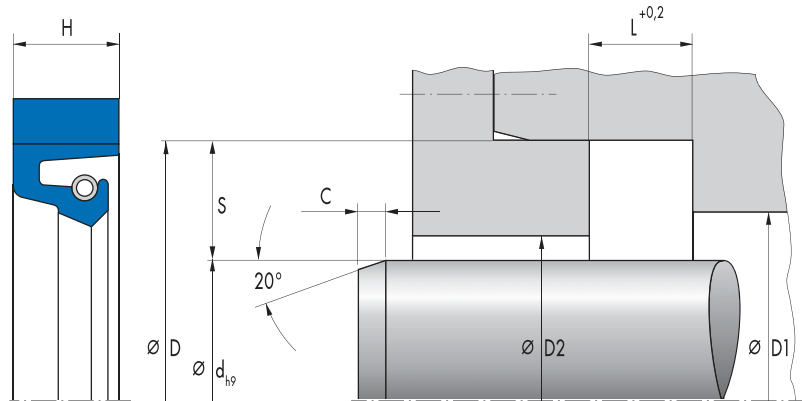

Width	D	L	D ₁	D ₂	C	Material	Article No.	
100	125	10	112,5	104	8	80 NBR B241	24019355	○
100	125	12,5	112,5	104	8	80 NBR B241	24019354	○
100	130	16	115	105	8	80 NBR B241	24084477	○
100	132	12,5	116	105	8	80 NBR B241	24019356	○
100	140	16	120	107	8	80 NBR B241	24199219	○
105	145	16	125	112	8	80 NBR B241	24091749	○
110	135	10	122,5	114	8	80 NBR B241	24019358	○
110	135	12,5	122,5	114	8	80 NBR B241	24019357	○
110	140	13	125	115	8	80 NBR B241	24019359	○
110	140	13	125	115	8	80 FKM K670	24294262	○
110	140	16	125	115	8	80 NBR B241	24084489	○
110	140	16	125	115	8	80 NBR B241	24375934	○
110	150	16	130	117	8	80 NBR B241	24029888	○
120	150	16	135	125	8	80 NBR B241	24084491	○
120	160	16	140	127	8	80 NBR B241	24019360	○
125	155	12	140	130	8	80 NBR B241	24019361	○
125	155	12	140	130	8	80 FKM K670	24197677	○
125	165	15,8	145	132	8	80 NBR B241	24127755	○
130	160	15	145	135	8	80 NBR B241	24019362	○
130	170	16	150	137	8	80 NBR B241	24019363	○
140	170	16	155	145	8	80 NBR B241	24111679	○
140	180	16	160	147	8	80 NBR B241	24019364	○
146	177,8	15,9	161,9	151	8	80 NBR B241	24019365	○
150	180	12,7	165	155	8	80 NBR B241	24099375	○
150	180	13	165	155	8	80 FKM K670	24296764	○
150	180	16	165	155	8	80 NBR B241	24084493	○
150	190	16	170	157	8	80 NBR B241	24019366	○
160	190	16	175	165	8	80 NBR B241	24111683	○
160	200	16	180	167	8	80 NBR B241	24019367	○
170	200	16	185	175	8	80 NBR B241	24119486	○
170	200	16	185	175	8	80 FKM K670	24235848	○
170	210	16	190	177	8	80 FKM K670	24224263	○
170	210	16	190	177	8	80 NBR B241	24019368	○
177,8	215,9	15,9	196,85	182,8	8	80 NBR B241	24099675	○
180	215	18	197,5	185	8	80 FKM K670	24301711	○

● Available from stock ○ On request: Tool is available, delivery at short notice

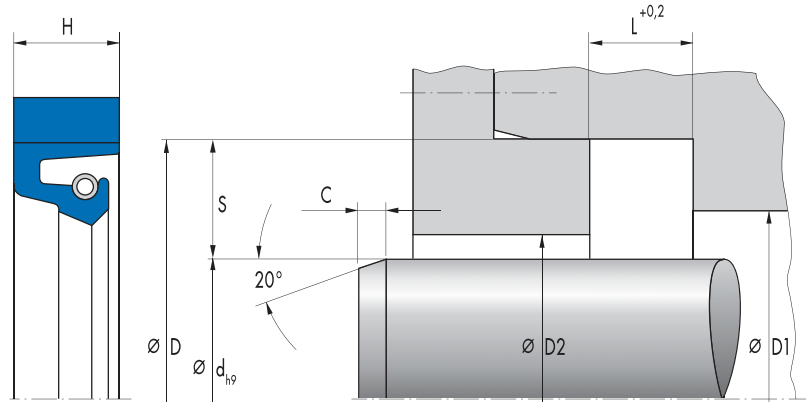

Width	D	L	D ₁	D ₂	C	Material	Article No.	
180	215	18	197,5	185	8	80 NBR B241	24111687	○
180	220	16	200	187	8	80 NBR B241	24080078	○
184,2	215,9	16	200,05	189,2	8	80 NBR B241	24089569	○
185	225	16	205	192	8	80 NBR B241	24019369	○
190	225	18	207,5	195	8	80 NBR B241	24084495	○
190	230	16	210	197	8	80 NBR B241	24093226	○
190	234	20	212	197	8	80 FKM K670	24343975	○
190,5	215,9	15,9	203,2	194,5	8	80 FKM K670	24193482	○
195	235	16	215	202	8	80 NBR B241	24019370	○
200	235	18	217,5	205	8	80 NBR B241	24111691	○
200	240	16	220	207	8	80 FKM K670	24332515	○
200	240	16	220	207	8	80 NBR B241	24019371	○
205	245	16	225	212	10	80 NBR B241	24075437	○
210	245	18	227,5	215	10	80 NBR B241	24111695	○
210	250	16	230	217	10	80 NBR B241	24056190	○
220	255	18	237,5	225	10	80 NBR B241	24109573	○
220	260	16	240	227	10	80 NBR B241	24019373	○
220	260	16	240	227	10	80 FKM K670	24180731	○
225	265	16	245	232	10	80 NBR B241	24076590	○
230	260	15,7	245	235	10	80 NBR B241	24107871	○
230	270	16	250	237	10	80 FKM K670	24260047	○
230	270	16	250	237	10	80 NBR B241	24019374	○
230	280	20	255	238	10	80 NBR B241	24019375	○
235	265	15	250	240	10	80 NBR B241	24082534	○
235	275	16	255	242	10	80 NBR B241	24055526	○
240	275	18	257,5	245	10	80 NBR B241	24084497	○
240	280	16	260	247	10	80 NBR B241	24019376	○
240	290	25	265	248	10	80 FKM K670	24343976	○
245	285	16	265	252	10	80 NBR B241	24019377	○
250	290	16	270	257	10	80 NBR B241	24019378	○
250	294	20	272	257	10	80 NBR B241	24019379	○
260	290	16	275	265	10	80 NBR B241	24019380	○
260	300	18	280	267	10	80 NBR B241	24111702	○
260	304	20	282	267	10	80 NBR B241	24029887	○
270	310	20	290	277	10	80 NBR B241	24084499	○
270	314	20	292	277	10	80 NBR B241	24019381	○

● Available from stock ○ On request: Tool is available, delivery at short notice

Width	D	L	D ₁	D ₂	C	Material	Article No.	
272	304	15,8	288	277	10	80 NBR B241	24107874	○
273,1	317,5	19,1	295,32	280,1	10	80 FKM K670	24088545	○
280	320	16	300	287	10	80 FKM K670	24330886	○
280	320	16	300	287	10	80 NBR B241	24030348	○
280	320	18	300	287	10	80 NBR B241	24084515	○
280	320	20	300	287	10	80 NBR B241	24084500	○
280	324	20	302	287	10	80 FKM K670	24343977	○
280	324	20	302	287	10	80 NBR B241	24019383	○
290	330	20	310	297	10	80 NBR B241	24111392	○
295	339	20	317	302	10	80 NBR B241	24030425	○
298,5	336,5	22	317,5	305,5	10	80 NBR B241	24183955	○
300	340	16	320	307	10	80 NBR B241	24019386	○
300	340	20	320	307	10	80 NBR B241	24019385	○
300	340	20	320	307	10	80 FKM K670	24172753	○
300	344	20	322	307	10	80 NBR B241	24019387	○
305	355	22,5	330	313	10	80 NBR B241	24019389	○
310	354	20	332	317	10	80 NBR B241	24019390	○
311	345	18	328	316	10	80 NBR B241	24019391	○
315	343	14	329	320	10	80 NBR B241	24019392	○
315	355	16	335	322	10	80 NBR B241	24019395	○
317,5	355,6	15,9	336,55	322,5	10	80 NBR B241	24019396	○
320	350	15	335	325	10	80 NBR B241	24056225	○
320	360	18	340	327	10	80 NBR B241	24019397	○
320	360	20	340	327	10	80 NBR B241	24111395	○
320	364	20	342	327	10	80 NBR B241	24019398	○
325	369	20	347	332	10	80 NBR B241	24019399	○
330	374	20	352	337	10	80 NBR B241	24019401	○
340	372	20	356	345	10	80 NBR B241	24224500	○
340	380	20	360	347	10	80 NBR B241	24084501	○
340	384	20	362	347	10	80 NBR B241	24019402	○
350	380	20	365	355	10	80 NBR B241	24093956	○
350	390	20	370	357	10	80 NBR B241	24109577	○
350	394	20	372	357	10	80 NBR B241	24019403	○
355	399	20	377	362	10	80 NBR B241	24107203	○
360	400	20	380	367	10	80 NBR B241	24119489	○
360	404	20	382	367	10	80 NBR B241	24019407	○
362	406	19,5	384	369	10	80 NBR B241	24019408	○
362	406	19,5	384	369	10	80 FKM K670	24230599	○
370	414	20	392	377	10	80 NBR B241	24019409	○
370	420	20	395	378	10	80 NBR B241	24019410	○
374,6	419,1	21,8	396,83	381,6	10	80 NBR B241	24019411	○
380	420	20	400	387	10	80 NBR B241	24197026	○
380	424	20	402	387	10	80 NBR B241	24019413	○
385	429	20	407	392	10	80 NBR B241	24083793	○
385	435	22	410	393	10	80 NBR B241	526464	○
385	435	22	410	393	10	80 NBR B241	24076585	○
390	434	20	412	397	10	80 NBR B241	24019416	○
395	439	20	417	402	10	80 NBR B241	24019417	○
400	440	20	420	407	10	80 NBR B241	24136765	○
400	444	20	422	407	10	80 NBR B241	24056607	○

● Available from stock ○ On request: Tool is available, delivery at short notice

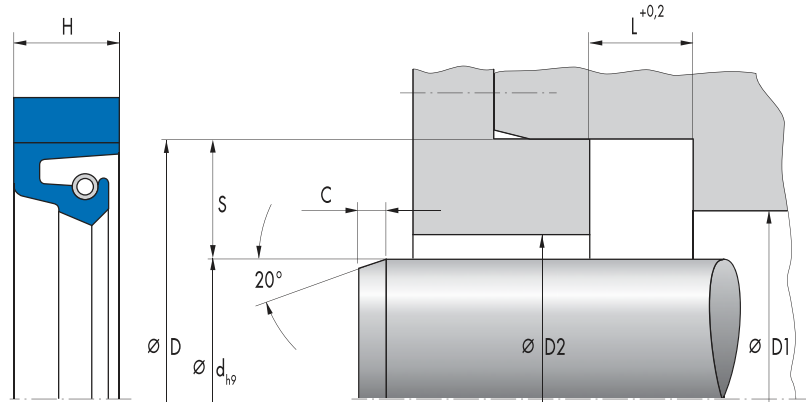

Width	D	L	D ₁	D ₂	C	Material	Article No.	
400	450	20	425	408	10	80 NBR B241	24019418	○
406,4	457,2	20,5	431,8	414,4	10	80 NBR B241	24069922	○
406,4	457,2	20,6	431,8	414,4	10	80 NBR B241	24019419	○
406,4	457,2	23	431,8	414,4	10	80 NBR B241	24019420	○
410	454	20	432	417	10	80 NBR B241	24078041	○
410	460	22	435	418	10	80 NBR B241	24029878	○
415	465	22	440	423	10	80 NBR B241	24019422	○
416	466	21,5	441	424	10	80 NBR B241	24019423	○
420	460	20	440	427	10	80 NBR B241	24074999	○
420	464	20	442	427	10	80 NBR B241	24027234	○
420	470	22	445	428	10	80 NBR B241	24019424	○
430	480	22	455	438	10	80 FKM K670	24335749	○
430	480	22	455	438	10	80 NBR B241	24019425	○
432	470	21,5	451	437	10	80 NBR B241	24096514	○
435	485	22	460	443	10	80 NBR B241	24019427	○
440	480	26	460	447	10	80 NBR B241	24019428	○
440	490	22	465	448	10	80 NBR B241	24019429	○
445	485	18	465	452	10	80 NBR B241	24019430	○
450	500	22	475	458	10	80 NBR B241	24019431	○
450	500	25	475	458	10	80 NBR B241	24084467	○
454	500	18	477	461	10	80 NBR B241	24030097	○
467	510	25	488,5	474	10	80 NBR B241	24019432	○
469,9	520,7	23	495,3	477,9	10	80 NBR B241	24019433	○
480	524	20	502	487	10	80 NBR B241	24027235	○
480	530	22	505	488	10	80 FKM K670	24335750	○
480	530	22	505	488	10	80 NBR B241	24084513	○
485	535	22	510	493	10	80 NBR B241	24019435	○
493	543	26	518	501	10	80 NBR B241	24056443	○
500	544	20	522	507	10	80 NBR B241	24073973	○
500	550	22	525	508	10	80 NBR B241	24019436	○
510	554	19,5	532	517	13	80 NBR B241	24019437	○
510	560	22	535	518	13	80 NBR B241	24237637	○
520	570	22	545	528	13	80 FKM K670	24335752	○
520	570	22	545	528	13	80 FKM K670	24375846	○
520	570	22	545	528	13	80 NBR B241	24019438	○
525	575	22	550	533	13	80 NBR B241	24023845	○

● Available from stock ○ On request: Tool is available, delivery at short notice

Width	D	L	D ₁	D ₂	C	Material	Article No.	
530	580	22	555	538	13	80 NBR B241	24019439	○
535	585	22	560	543	13	80 NBR B241	24056753	○
540	585	18	562,5	547	13	80 NBR B241	24030244	○
540	590	22	565	548	13	80 NBR B241	24224493	○
550	600	23,5	575	558	13	80 NBR B241	24019440	○
560	610	22	585	568	13	80 NBR B241	24019441	○
565	615	22	590	573	13	80 NBR B241	24083897	○
570	620	22	595	578	13	80 NBR B241	24019442	○
580	630	22	605	588	13	80 NBR B241	24019443	○
585	635	22	610	593	13	80 NBR B241	24074892	○
590	640	22	615	598	13	80 NBR B241	24098918	○
600	650	22	625	608	13	80 NBR B241	24083894	○
600	650	22	625	608	13	80 NBR B241	24377650	○
600	660	30	630	610	13	80 NBR B241	24209235	○
610	674	25	642	620	13	80 NBR B241	24019445	○
620	684	25	652	630	13	80 NBR B241	24019446	○
625	655	20	640	630	13	80 NBR B241	24069422	○
636	692	30,5	664	646	13	80 NBR B241	24019447	○
640	684	20	662	647	13	80 NBR B241	24019448	○
640	704	25	672	650	13	80 NBR B241	24079885	○
660	704	20	682	667	13	80 NBR B241	24079888	○
660,4	711,2	25,4	685,8	668,4	13	80 NBR B241	24019449	○
670	734	25	702	680	13	80 NBR B241	24019450	○
680	730	20	705	688	13	80 FKM K670	24335413	○
680	730	20	705	688	13	80 NBR B241	24056485	○
685	737	22	711	693	13	80 NBR B241	24288861	○
690	740	22	715	698	13	80 NBR B241	24109964	○
690	754	25	722	700	13	80 NBR B241	24060652	○
698,5	749,3	22,2	723,9	706,5	13	80 NBR B241	24019451	○
700	764	25	732	710	13	80 NBR B241	24086435	○
710	760	20	735	718	13	80 NBR B241	24080021	○
730	770	20	750	737	13	80 NBR B241	24214616	○
730	794	25	762	740	13	80 NBR B241	24019452	○
735	799	25	767	745	13	80 NBR B241	24019453	○
750	810	25	780	760	13	80 NBR B241	24058322	○
760	800	20	780	767	13	80 NBR B241	24114592	○
760	804	20	782	767	13	80 NBR B241	24027238	○
760	820	25	790	770	13	80 NBR B241	24257072	○
770	834	25	802	780	13	80 NBR B241	24019454	○
776	820	20	798	783	13	80 FKM K670	24335414	○
780	844	25	812	790	13	80 NBR B241	24030498	○
799	860	26	829,5	809	13	80 NBR B241	24023846	○
800	864	25	832	810	13	80 NBR B241	24019456	○
805	869	25	837	815	16	80 NBR B241	24019457	○
830	894	25	862	840	16	80 NBR B241	24130473	○
835	899	25	867	845	16	80 NBR B241	24019458	○
840	904	25	872	850	16	80 NBR B241	24078229	○
860	920	25	890	870	16	80 NBR B241	24130477	○
860	924	25	892	870	16	80 NBR B241	24063681	○
880	940	30	910	890	16	80 NBR B241	24209239	○

● Available from stock ○ On request: Tool is available, delivery at short notice

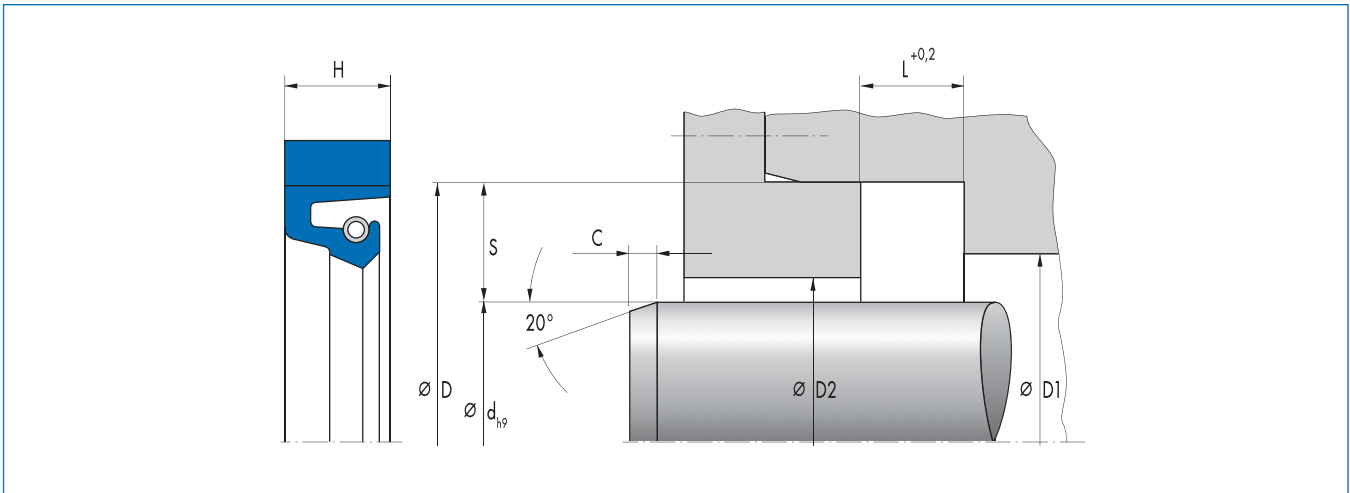

Width	D	L	D ₁	D ₂	C	Material	Article No.	
880	944	25	912	890	16	80 NBR B241	24019459	○
890	954	25	922	900	16	80 NBR B241	24023847	○
900	960	27	930	910	16	80 NBR B241	24177298	○
910	974	25	942	920	16	80 NBR B241	24019460	○
930	994	25	962	940	16	80 NBR B241	24027236	○
950	1014	25	982	960	16	80 NBR B241	24266520	○
955	1019	25	987	965	16	80 NBR B241	24300376	○
970	1034	25	1002	980	16	80 NBR B241	24019462	○
1000	1060	30	1030	1010	16	80 NBR B241	24209243	○
1000	1064	25	1032	1010	16	80 NBR B241	24109960	○
1020	1084	25	1052	1030	16	80 NBR B241	24019464	○
1060	1124	25	1092	1070	16	80 NBR B241	24121892	○
1110	1174	25	1142	1120	16	80 NBR B241	24060654	○
1130	1194	25	1162	1140	16	80 NBR B241	24065116	○
1175	1239	25	1207	1185	16	80 NBR B241	524751	○
1200	1264	25	1232	1210	16	80 NBR B241	24027475	○
1435	1499	25	1467	1445	20	80 NBR B241	24121165	○
1480	1544	25	1512	1490	20	80 NBR B241	24052248	○

● Available from stock ○ On request: Tool is available, delivery at short notice

Simmerring Radiamatic® R 36

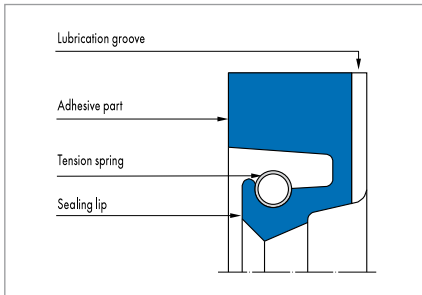

Fig. 1 Simmerring Radiamatic® R 36

Product description

Simmerring with a fabric reinforced static part that is securely joined to the elastomer sealing lip. The sealing lip is also pre-loaded with a garter spring.

Product advantages

Sealing ring is used, in case of adequate lubrication by the medium to be sealed, preferably where shafts pass through walls in mills and large gearboxes in heavy machinery manufacture.

- Particularly robust static part
- Lasting radial contact pressure
- Highly wear-resistant
- With design measures, e.g., metal support for the sealing lip, higher pressures are possible
- Overpressure requires the usage of endless seals
- Back-up ring drawings and installation instructions for open seals are available.

Application

Mills, ship building, steel hydraulics engineering, wind power plants.

Material

Sealing lip	Static part	Tension spring
80 NBR B241	Impregnated cotton fabric B4 B248	ST 1.4571
80 FKM K670	Impregnated aramide fabric	ST 1.4571
75 HNBR U467	Impregnated aramide fabric C2 U464	ST 1.4571

Operating conditions

Material	80 NBR B241	80 FKM K670	75 HNBR U467
	Temperature range in °C		
Mineral oils	-30 ... +100	-10 ... +180	-20 ... +140
Water	+5 ... +100	+5 ... +80	+5 ... +100
Lubricating greases	-30 ... +100	-10 ... +180	-20 ... +140
Rolling oil emulsion	on enquiry		
Pressure p in MPa	0,05		
Running speed v in m/s	20	25	250

Other media on enquiry. Application parameters are recommended values, do not utilise all parameters simultaneously.

Surface quality

Peak-to-valley heights	R _a	R _{max}
Running surface	≤0,6 µm	≤2,5 µm
Housing	≤4 µm	≤15 µm

The contact area is machined by plunge grinding, i.e. without feed. The surface hardness must be approx. 60 HRC (depth of hardening min. 0,5 mm). With increasing circumferential speed the contact area should be manufactured with increasing peak-to-valley heights R_a. The surface should not be too smooth so that an adequate film of lubricant can form. Recommended value: R_{a min} = 0,1 µm. Percentage contact area M_r >50% to max. 90% at cutting depth c = Rz/2 and reference line C ref = 0%. Abrasive surfaces, ridges, scratches and blow-holes are to be avoided.

Design notes

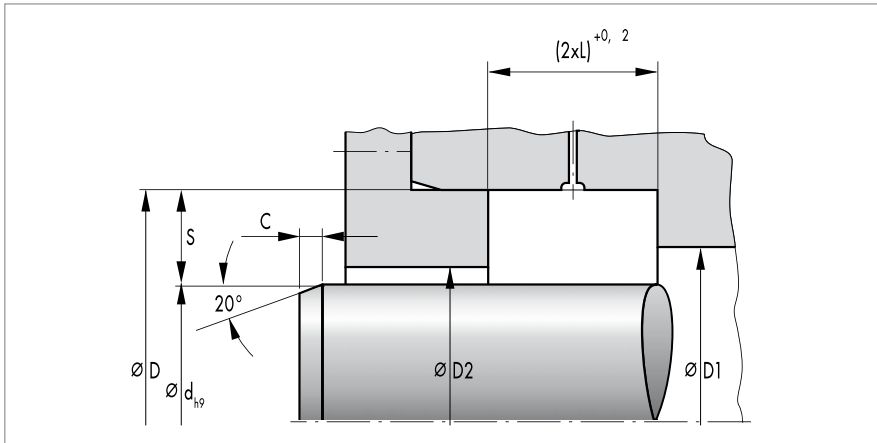

Fig. 2

Lead-in chamfers

See dimension "C" in the article list.

Tolerances

D	Tolerance
<500	H8
>500	+0,0004 x D

Overall eccentricity

The permissible overall eccentricity (static and dynamic eccentricity) between shaft and housing is dependent on the seal profile and circumferential speed. If necessary, we will provide recommended values.

Housing recommendations for new designs

d	S (Profile)	L
>100	20	16
>250	22	20
<450	25	22
>750	32	25

Fitting & installation

For Simmerring Radiamatic R 36 an axially accessible housing is necessary, as the rings must have low inclination. The Radiamatic R 36 rings are supplied with oversize seal width. For reliable function the Radiamatic R rings must be axially compressed to the dimension "L". An open housing with cover plate and tightening screws is necessary. Specific deformation forces are necessary for the compression. The cover plate and the tightening screws are to be designed appropriately. Please request recommended values.

Article list

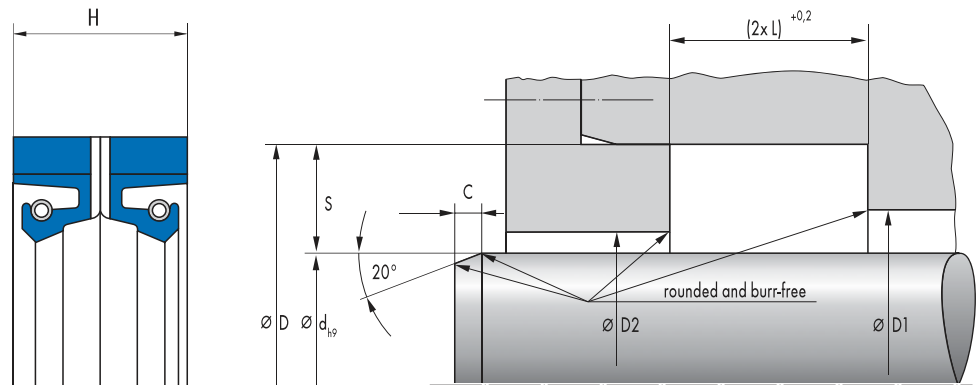

Width	D	L	D ₁	D ₂	C	Material	Article No.	
156	196	16	176	163	8	80 NBR B241	24060486	○
200	240	16	220	207	8	80 NBR B241	24292849	○
220	260	16	240	227	10	80 NBR B241	24145056	○
260	290	16	275	265	10	80 NBR B241	24019466	○
275	319,5	19	297,25	282	10	80 NBR B241	24120742	○
280	320	16	300	287	10	80 NBR B241	24119507	○
320	355	16	337,5	325	10	80 NBR B241	24019468	○
330	374	20	352	337	10	80 NBR B241	24088367	○
335	375	15	355	342	10	80 NBR B241	24060450	○
350	394	20	372	357	10	80 NBR B241	24099447	○
380	424	20	402	387	10	80 NBR B241	24019469	○
400	440	21,9	420	407	10	80 NBR B241	24136768	○
400	450	22	425	408	10	80 NBR B241	24054744	○
400,1	438,2	19,1	419,15	405,1	10	80 NBR B241	24019470	○
430	480	22	455	438	10	80 NBR B241	24019471	○
445	495	22	470	453	10	80 NBR B241	24019472	○
460	510	22	485	468	10	80 NBR B241	24019473	○
470	520	22	495	478	10	80 NBR B241	24019474	○
515	565	22	540	523	13	80 NBR B241	24019475	○
570	620	22	595	578	13	80 NBR B241	24054745	○
592	642	22	617	600	13	80 NBR B241	24019476	○
610	660	22	635	618	13	80 NBR B241	24077194	○
625	689	25	657	635	13	80 NBR B241	24054746	○
650	700	22	675	658	13	80 NBR B241	24019477	○
650	714	25	682	660	13	80 NBR B241	24019478	○
676	740	25	708	686	13	80 NBR B241	24019480	○
710	760	25	735	718	13	80 NBR B241	24019481	○
710	774	25	742	720	13	80 NBR B241	24095916	○
735	799	25	767	745	13	80 NBR B241	24075431	○
820	884	28	852	830	16	80 NBR B241	24019482	○
830	894	28	862	840	16	80 NBR B241	24019483	○
835	894	28	864,5	845	16	80 NBR B241	24340276	○
840	904	28	872	850	16	80 NBR B241	24056636	○
850	910	25	880	860	16	80 NBR B241	24019484	○
1020	1084	25	1052	1030	16	80 NBR B241	24059867	○

● Available from stock ○ On request: Tool is available, delivery at short notice

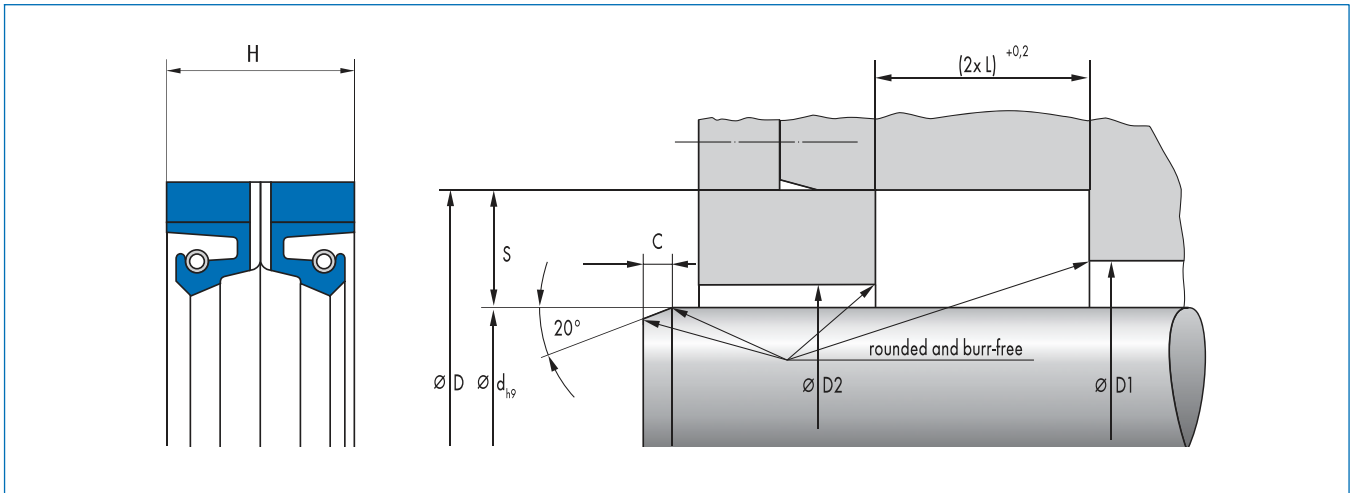

Width	D	L	D ₁	D ₂	C	Material	Article No.	
1100	1160	25	1130	1110	16	80 NBR B241	24019487	<input type="radio"/>

● Available from stock ○ On request: Tool is available, delivery at short notice

Simmerring Radiamatic® R 37

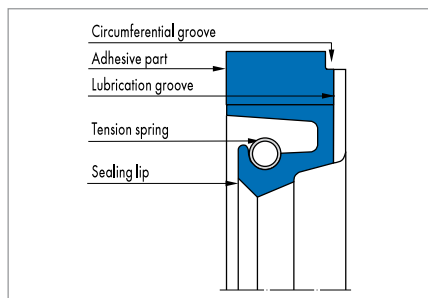

Fig. 1 Simmerring Radiamatic® R 37

Product description

Simmerring with a fabric reinforced static part that is securely joined to the elastomer sealing lip. The sealing lip is also pre-loaded with a garter spring.

Product advantages

Sealing ring is used, in case of adequate lubrication by the medium to be sealed, preferably where shafts pass through walls in mills and large gearboxes in heavy machinery manufacture.

- Particularly robust static part
- Lasting radial contact pressure
- Highly wear-resistant.

Application

Mills, ship building, steel hydraulics engineering, wind power plants.

Material

Sealing lip	Static part	Tension spring
80 NBR B241	Impregnated cotton fabric B4 B248	ST 1.4571
80 FKM K670	Impregnated aramide fabric C2K670	ST 1.4571
75 HNBR U467	Impregnated aramide fabric C2U464	ST 1.4571

Operating conditions

Material	80 NBR B241	80 FKM K670	75 HNBR U467
	Temperature range in °C		
Mineral oils	-30 ... +100	-10 ... +180	-20 ... +140
Water	+5 ... +100	+5 ... +80	+5 ... +100
Lubricating greases	-30 ... +100	-10 ... +180	-20 ... +140
Rolling oil emulsion	on enquiry		
Pressure p in MPa	0,05		
Running speed v in m/s	20	25	250

Other media on enquiry. Application parameters are recommended values, do not utilise all parameters simultaneously.

Surface quality

Peak-to-valley heights	R _a	R _{max}
Running surface	≤0,6 µm	≤2,5 µm
Housing	≤4 µm	≤15 µm

The contact area is machined by plunge grinding, i.e. without feed. The surface hardness must be approx. 60 HRC (depth of hardening min. 0,5 mm). With increasing circumferential speed the contact area should be manufactured with increasing peak-to-valley heights R_a. The surface should not be too smooth so that an adequate film of lubricant can form. Recommended value: R_{a min} = 0,1 µm. Percentage contact area M_v >50% to max. 90% at cutting depth c = Rz/2 and reference line C ref = 0%. Abrasive surfaces, ridges, scratches and blow-holes are to be avoided.

Design notes

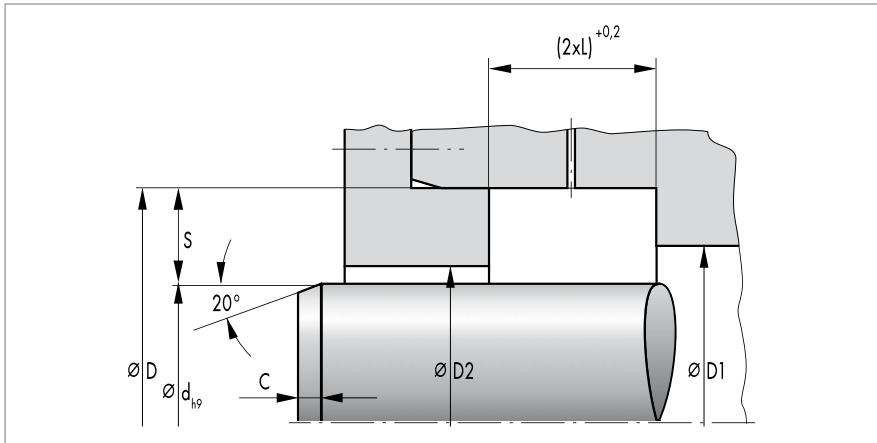

Fig. 2

Lead-in chamfers

See dimension "C" in the article list.

Tolerances

D	Tolerance
<500	H8
>500	+0,0004 x D

Overall eccentricity

The permissible overall eccentricity (static and dynamic eccentricity) between shaft and housing is dependent on the seal profile and circumferential speed. If necessary, we will provide recommended values.

Housing recommendations for new designs

d	S (Profile)	L
>100	20	16
>250	22	20
<450	25	22
>750	32	25

Fitting & installation

For Simmerring Radiamatic R 37 an axially accessible housing is necessary, as the rings must have low inclination. The Radiamatic R 37 rings are supplied with oversize seal width. For reliable function the Radiamatic R rings must be axially compressed to the dimension "L". An open housing with cover plate and tightening screws is necessary. Specific deformation forces are necessary for the compression. The cover plate and the tightening screws are to be designed appropriately. Please request recommended values.

Article list

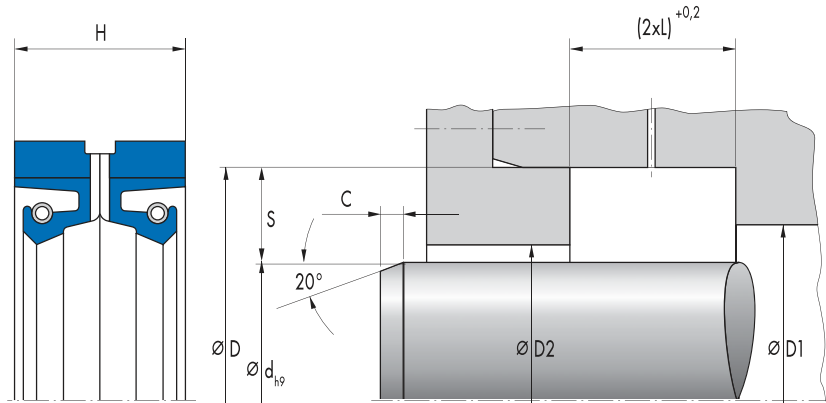

Width	D	L	D ₁	D ₂	C	Material	Article No.	
101,6	133,3	11,9	117,45	106,6	8	80 NBR B241	24019488	○
127	158,8	12,3	142,9	134	8	80 NBR B241	24084424	○
127	158,8	12,5	142,9	134	8	80 FKM K670	24316571	○
132,5	172,5	16	152,5	139,5	8	80 NBR B241	24102306	○
133	165	12,5	149	138	8	80 NBR B241	24029891	○
160	190	14,3	175	165	10	80 NBR B241	24233697	○
160	200	18	180	167	10	80 NBR B241	24019489	○
170	200	13	185	175	10	80 NBR B241	24039649	○
170	210	18	190	177	10	80 NBR B241	24128280	○
175	205	14,5	190	180	10	80 NBR B241	24242046	○
175	215	16	195	182	10	80 NBR B241	24027243	○
180	210	14	195	185	10	80 NBR B241	24051648	○
185	225	16	205	192	10	80 FKM K670	24264958	○
195	225	14,5	210	200	10	80 NBR B241	24242055	○
200	230	14	215	205	10	80 FKM K670	24292790	○
200	230	14	215	205	10	80 NBR B241	24051248	○
220	250	16	235	225	10	80 NBR B241	24051448	○
220	260	16	240	227	10	80 NBR B241	24035849	○
230	260	16	245	235	10	80 NBR B241	24234870	○
230	270	16	250	237	10	80 NBR B241	24181867	○
230	280	22,5	255	238	10	80 NBR B241	24019490	○
235	265	15	250	240	10	80 NBR B241	24339504	○
245	285	16	265	252	10	80 NBR B241	24352034	○
250	280	16	265	255	10	80 NBR B241	24051548	○
250	290	16	270	257	10	80 NBR B241	24035749	○
260	300	14	280	267	10	80 NBR B241	24051348	○
270	310	18	290	277	10	80 NBR B241	24030228	○
275	315	18	295	282	10	80 NBR B241	24142291	○
290	334	20	312	297	10	80 NBR B241	24052348	○
292,1	330,2	19,4	312,65	299,1	10	80 NBR B241	24180004	○
300	340	16	320	307	10	80 NBR B241	24230747	○
300	344	20	322	307	10	80 NBR B241	24055100	○
320	360	17,7	340	327	10	80 NBR B241	24141749	○
320	364	20	342	327	10	80 NBR B241	24237636	○
325	375	22,5	350	333	10	80 NBR B241	24019493	○

● Available from stock ○ On request: Tool is available, delivery at short notice

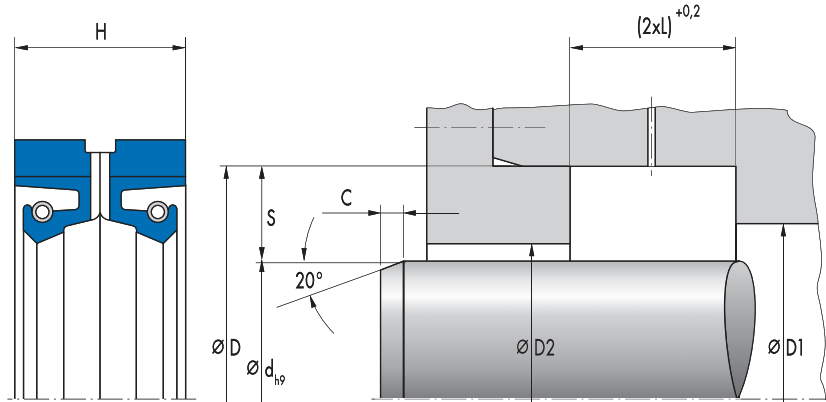

Width	D	L	D ₁	D ₂	C	Material	Article No.	
330	374	20	352	337	10	80 NBR B241	24143075	○
330,2	368,3	22,2	349,25	337,2	10	80 NBR B241	24170623	○
345	389	20	367	352	10	80 NBR B241	24143071	○
350	394	20	372	357	10	80 NBR B241	24264183	○
350	394	20	372	357	10	80 FKM K670	24292794	○
360	404	20	382	367	10	80 NBR B241	24090860	○
370	414	20	392	377	10	80 NBR B241	24183874	○
370	414	20	392	377	10	80 FKM K670	24302799	○
380	424	20	402	387	10	80 NBR B241	24143083	○
387	431	22	409	394	10	80 NBR B241	24019494	○
395	439	22	417	402	10	80 NBR B241	24030420	○
400	444	20	422	407	10	80 NBR B241	24090862	○
400	450	22	425	408	10	80 NBR B241	24085941	○
420	470	22	445	428	10	80 NBR B241	24019496	○
430	480	22	455	438	10	80 NBR B241	24019497	○
435	485	22	460	443	10	80 NBR B241	24080564	○
440	490	28	465	448	10	80 NBR B241	24080542	○
445	485	18	465	452	10	80 NBR B241	24316607	○
446	486	16	466	453	10	80 NBR B241	24055680	○
454	504,8	21	479,4	462	10	80 NBR B241	24023848	○
455	505	25	480	463	10	80 NBR B241	24019499	○
470	520	22	495	478	10	80 NBR B241	24030349	○
480	530	22	505	488	10	80 NBR B241	24346715	○
480	530	25	505	488	10	80 NBR B241	24019500	○
500	545	20	522,5	507	10	80 NBR B241	24073136	○
500	550	22	525	508	10	80 FKM K670	24351569	○
500	550	22	525	508	10	80 NBR B241	24029886	○
530	580	22	555	538	13	80 FKM K670	24330883	○
530	580	22	555	538	13	80 NBR B241	24079020	○
535	585	22	560	543	13	80 NBR B241	24377408	○
540	590	22	565	548	13	80 NBR B241	24027244	○
540	590	25	565	548	13	80 NBR B241	24019502	○
560	604	20	582	567	13	80 NBR B241	24019503	○
560	610	22	585	568	13	80 FKM K670	24142097	○
565	615	22	590	573	13	80 NBR B241	24377407	○
580	630	22	605	588	13	80 NBR B241	24241448	○

● Available from stock ○ On request: Tool is available, delivery at short notice

Width	D	L	D ₁	D ₂	C	Material	Article No.	
590	640	22	615	598	13	80 NBR B241	24029885	○
596	652	29,5	624	606	13	80 NBR B241	24030419	○
600	650	22	625	608	13	80 NBR B241	24092311	○
609,6	660,4	22	635	617,6	13	80 NBR B241	24183145	○
616	666,8	22	641,4	624	13	80 NBR B241	24296689	○
620	684	25	652	630	13	80 NBR B241	24173794	○
640	684	20	662	647	13	80 NBR B241	24019505	○
650	714	25	682	660	13	80 NBR B241	24019506	○
660	700	18	680	667	13	80 NBR B241	24147946	○
670	714	22	692	677	13	80 NBR B241	24019507	○
680	730	22	705	688	13	80 NBR B241	24143002	○
685,8	749,3	25	717,55	695,8	13	80 NBR B241	24179979	○
700	750	25	725	708	13	80 NBR B241	24144899	○
710	760	25	735	718	13	80 NBR B241	24030492	○
710	774	25	742	720	13	80 NBR B241	24138786	○
720	780	25	750	730	13	80 NBR B241	24138770	○
720	780	25	750	730	13	80 FKM K670	24335751	○
735	799	25	767	745	13	80 FKM K670	24335411	○
750	814	25	782	760	13	80 NBR B241	24239267	○
750	814	28	782	760	13	80 NBR B241	24019508	○
760	804	20	782	767	13	80 NBR B241	24092067	○
775	839	25	807	785	13	80 NBR B241	24078227	○
780	820	17,7	800	787	13	80 NBR B241	24141753	○
780	844	25	812	790	13	80 NBR B241	24102054	○
800	864	25	832	810	13	80 NBR B241	24139749	○
810	874	25	842	820	16	80 NBR B241	24019509	○
820	870	25	845	828	16	80 NBR B241	24138778	○
860	920	22	890	870	16	80 FKM K670	24260998	○
860	920	22	890	870	16	80 NBR B241	24019510	○
870	930	27	900	880	16	80 NBR B241	24077687	○
870	934	25	902	880	16	80 NBR B241	24030422	○
880	944	25	912	890	16	80 NBR B241	24039949	○
970	1030	21,5	1000	980	16	80 NBR B241	24019511	○
985	1045	24,5	1015	995	16	80 NBR B241	24066979	○
1080	1140	25	1110	1090	16	80 FKM K670	24335407	○
1220	1284	25	1252	1230	20	80 NBR B241	24060650	○
1250	1314	25	1282	1260	20	80 FKM K670	24215196	○
1250	1314	25	1282	1260	20	80 NBR B241	24090489	○
1330	1394	25	1362	1340	20	80 NBR B241	24290261	○
1608,5	1670	20	1639,25	1618	20	80 NBR B241	24055983	○
1610	1670	20	1640	1620	20	80 NBR B241	24027477	○
1740	1800	20	1770	1750	20	80 NBR B241	24055944	○

● Available from stock ○ On request: Tool is available, delivery at short notice

Simmerring Radiamatic® R 58

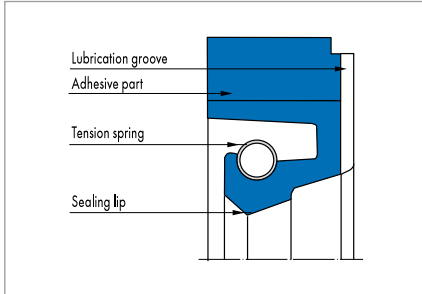

Fig. 1 Simmerring Radiamatic® R 58

Product description

Simmerring with a fabric reinforced static part that is securely joined to the elastomer sealing lip. The sealing lip is also pre-loaded with a garter spring.

Product advantages

The sealing ring has a groove around the circumference to facilitate additional lubrication from the outside. The Simmerring Radiamatic R 58 was developed for the special requirements of grease-lubricated bearings in mill manufacture.

- Particularly robust static part
- Lasting radial contact pressure
- Highly wear-resistant.

Application

Mills.

Material

Sealing lip	Static part	Tension spring
80 NBR B241	Impregnated cotton fabric B4 B248	ST 1.4571

Other materials on enquiry.

Operating conditions

Material	80 NBR B241
Temperature range in °C	
Mineral oils	-30 ... +100
Water	+5 ... +100
Lubricating greases	-30 ... +100
Rolling oil emulsion	on enquiry
Pressure p in MPa	0,05
Running speed v in m/s	15

Other media on enquiry. Application parameters are recommended values, do not utilise all parameters simultaneously.

Surface quality

Peak-to-valley heights	R _a	R _{max}
Running surface	≤0,6 µm	≤2,5 µm
Housing	≤4 µm	≤15 µm

The contact area is machined by plunge grinding, i.e. without feed. The surface hardness must be approx. 60 HRC (depth of hardening min. 0,5 mm). With increasing circumferential speed the contact area should be manufactured with increasing peak-to-valley heights R_a. The surface should not be too smooth so that an adequate film of lubricant can form. Recommended value: R_{a min} = 0,1 µm. Percentage contact area M_v >50% to max. 90% at cutting depth c = Rz/2 and reference line C ref = 0%. Abrasive surfaces, ridges, scratches and blow-holes are to be avoided.

Design notes

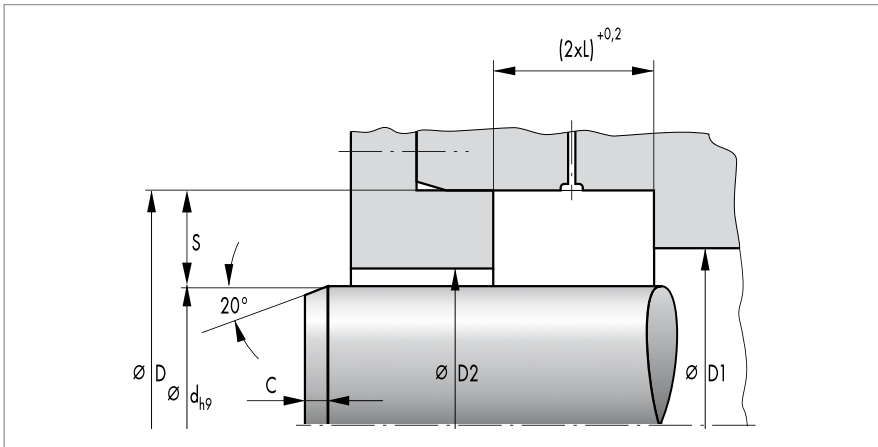

Fig. 2

Lead-in chamfers

See dimension "C" in the article list.

Tolerances

D	Tolerance
<500	H8
>500	+0,0004 x D

Overall eccentricity

The permissible overall eccentricity (static and dynamic eccentricity) between shaft and housing is dependent on the seal profile and circumferential speed. If necessary, we will provide recommended values.

Housing recommendations for new designs

d	S (Profile)	L
>100	20	16
>250	22	20
<450	25	22
>750	32	25

Fitting & installation

For Simmerring Radiamatic R 58 an axially accessible housing is necessary, as the rings must have low inclination. The Radiamatic R 58 rings are supplied with oversize seal width. For reliable function the Radiamatic R rings must be axially compressed to the dimension "L". An open housing with cover plate and tightening screws is necessary. Specific deformation forces are necessary for the compression. The cover plate and the tightening screws are to be designed appropriately. Please request recommended values.

Article list

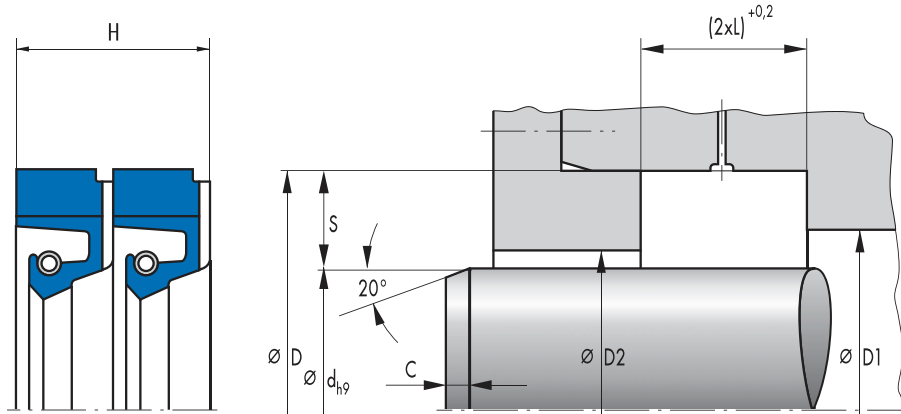

Width	D	L	D ₁	D ₂	C	Material	Article No.	
345	389	20	367	352	10	80 NBR B241	24330193	○
360	404	20	382	367	10	80 NBR B241	24349035	○
400	444	20	422	407	10	80 NBR B241	24349036	○
430	480	22	455	438	10	80 NBR B241	24349033	○
435	485	22	460	443	10	80 NBR B241	24313903	○
440	480	20	465	438	10	80 NBR B241	24351547	○
440	490	28	465	448	10	80 NBR B241	24330194	○
455	505	22	480	463	10	80 NBR B241	24378064	○
455	505	22	480	463	10	75 NBR B244	24346279	○
480	530	25	505	488	10	80 NBR B241	24313904	○
485	535	22	510	493	10	80 NBR B241	24313920	○
500	550	22	525	508	10	80 NBR B241	24315279	○
525	575	22	550	533	13	80 NBR B241	24313919	○
530	580	22	555	538	13	80 NBR B241	24315505	○
550	600	22	575	558	13	80 NBR B241	24315506	○
560	604	20	582	567	13	80 NBR B241	24349034	○
560	610	22	585	568	13	80 NBR B241	24315507	○
620	684	25	652	630	13	80 NBR B241	24315278	○
750	814	28	782	760	13	80 NBR B241	24315280	○
880	944	25	912	890	16	80 NBR B241	24315287	○

● Available from stock ○ On request: Tool is available, delivery at short notice

Simmerring Radiamatic® R 35 LD

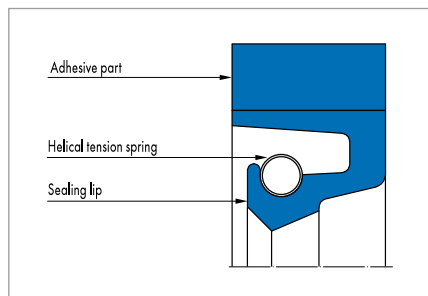

Fig. 1 Simmerring Radiamatic® R 35 LD

Product description

Simmerring with a fabric reinforced static part that is securely joined to the elastomer sealing lip. The sealing lip is also pre-loaded with a garter spring.

Product advantages

Sealing ring is used, in case of adequate lubrication by the medium to be sealed, preferably where shafts pass through walls in mills and large gearboxes in heavy machinery manufacture.

- Particularly robust static part
- Lasting radial contact pressure
- Highly wear-resistant.

Higher pressures are possible with design measures, e.g. metal support for the sealing lip. Overpressure requires the usage of endless seals. Back-up ring drawings and installation instructions for open seals are available.

Application

Mills, ship building.

Material

Sealing lip	Static part	Tension spring
80 NBR B241	Impregnated cotton fabric B4 B248	ST 1.4571
70 HNBR U467	Impregnated cotton fabric C2 U464	ST 1.4571

Operating conditions

Material	80 NBR B241	75 HNBR U467
	Temperature range in °C	
Mineral oils	-30 ... +100	-20 ... +140
Water	+5 ... +100	+5 ... +100
Lubricating greases	-30 ... +100	-20 ... +140
Rolling oil emulsion	on enquiry	
Pressure p in MPa	0,05	
Running speed v in m/s	20 (NBR), 25 (HNBR)	

Other media on enquiry. Application parameters are recommended values, do not utilise all parameters simultaneously.

Surface quality

Peak-to-valley heights	R _a	R _{max}
Running surface	≤0,6 µm	≤2,5 µm
Housing	≤4,0 µm	≤15,0 µm

The contact area is machined by plunge grinding, i.e. without feed. The surface hardness must be approx. 60 HRC (depth of hardening min. 0,5 mm). With increasing circumferential speed the contact area should be manufactured with increasing peak-to-valley heights R_a. The surface should not be too smooth so that an adequate film of lubricant can form. Recommended value: R_{a min} = 0,1 µm. Percentage contact area M_p >50% to max. 90% at cutting depth c = Rz/2 and reference line C ref = 0%. Abrasive surfaces, ridges, scratches and blow-holes are to be avoided.

Design notes

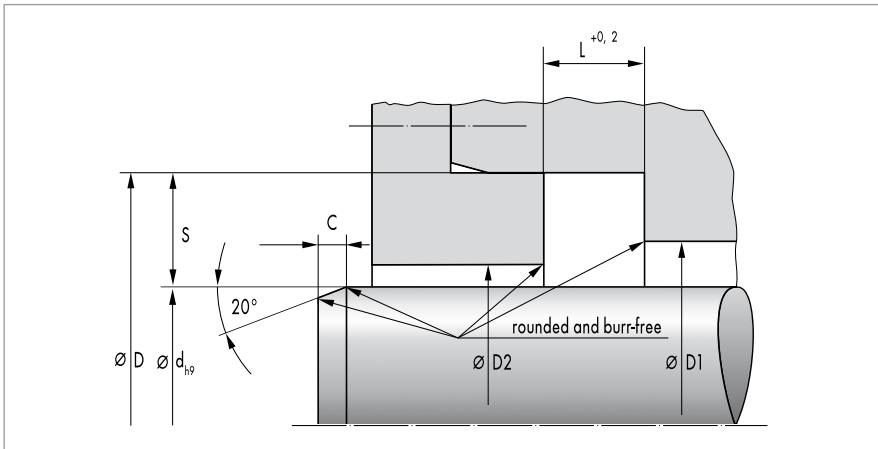

Fig. 2

Available dimensions

Profile S x L	Ø range
32 x 25	d > 1100 ... 3000

Simmerring Radiamatic® RS 85

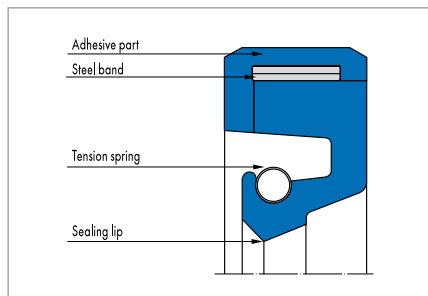

Fig. 1 Simmerring Radiamatic® RS 85

Product description

Self-holding Simmerring made from two functionally suitable elastomer components and an integrated steel strip. The tension springs support the radial contact pressure on the shaft.

Product advantages

Self-holding Simmerring for shaft pass through walls in heavy machinery manufacture.

- Long-lasting tight fit
- Lasting radial contact pressure
- Highly wear-resistant.

An axially accessible housing is necessary for the fitting. The non-pressurised side of the sealing ring is to be reinforced for pressurisation. In the unpressurised state, an axial reinforcement on the non-pressurised side is not necessary. Only endless self-holding Simmerrings Radiamatic RS 85 are available.

Application

Rolling mills, large gearboxes.

Material

Sealing lip	Static part	Steel strip	Tension spring
80 NBR B241	85 NBR B247	ST 1.4310	ST 1.4571
75 HNBR U467	85 HNBR 10040	ST 1.4310	ST 1.4571
80 FKM K670	90 FKM K683	ST 1.4310	ST 1.4571

Operating conditions

Material	80 NBR B241	75 HNBR U467	80 FKM K670
	Temperature range in °C		
Mineral oils	-30 ... +100	-20 ... +140	-10 ... +180
Water	+5 ... +100	+5 ... +100	+5 ... +80
Lubricating greases	-30 ... +100	-20 ... +140	-10 ... +180
Rolling oil emulsion	on enquiry		
Pressure p in MPa	0,05		
Running speed v in m/s	20	25	25

Other media on enquiry. Application parameters are recommended values, do not utilise all parameters simultaneously.

Surface quality

Peak-to-valley heights	R _a	R _{max}
Running surface	≤0,6 µm	≤2,5 µm
Housing	≤4,0 µm	≤15,0 µm

The contact area is machined by plunge grinding, i.e. without feed. The surface hardness must be approx. 60 HRC (depth of hardening min. 0,5 mm). With increasing circumferential speed, the contact area should be manufactured with increasing peak-to-valley heights R_z. The surface should not be too smooth so that an adequate film of lubricant can form. Recommended value: R_{a min} = 0,1 µm. Percentage contact area M_r >50% to max. 90% at cutting depth c = Rz/2 and reference line C ref = 0%. Abrasive surfaces, ridges, scratches and blow-holes are to be avoided.

Design notes

Please observe our general design notes in → Technical Manual.

Fitting & installation

Careful fitting is a prerequisite for the correct function of the seal. → Technical Manual.

Housing recommendations for new designs

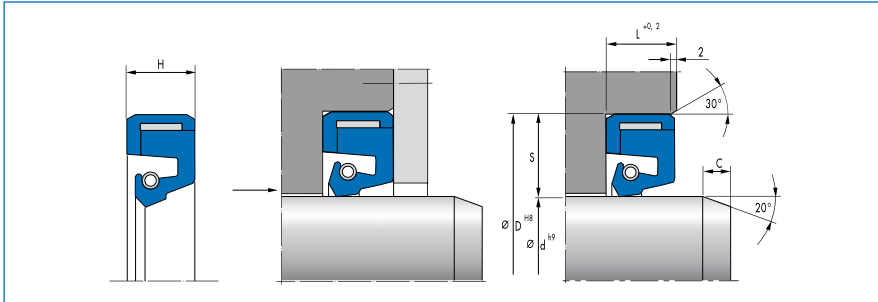

Ø d	S (Profile)	L	a
200 ... 450	20	20	4
	22	20	4
>450 ... 750	22	22	4
	25	22	4
>750	25	25	5
	30	25	5
	32	25	5

Lead-in chamfer

Ø d	c
<200	8
>200 ... 500	10
>500 ... 800	13
>800 ... 1200	16
>1200	20

Simmerring Radiamatic® RHS 51

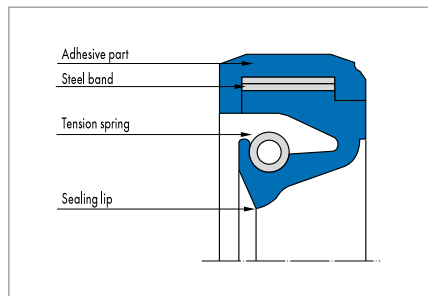

Fig. 1 Simmerring Radiamatic® RHS 51

Product description

High-speed Simmerring made from two functionally suitable elastomer components and an integrated steel strip. Two interleaved tension springs ensure an even radial force over the entire circumference length of the sealing edge even with high shaft centre offset.

Product advantages

Self-holding Simmerring for shaft pass through walls in mills and large gearboxes in heavy machinery manufacture. The sealing ring has radial grooves to facilitate additional lubrication from outside. Only endless self-holding Simmerrings are available

- Long-lasting tight fit
- Lasting radial contact pressure
- Highly wear-resistant
- High permissible shaft offset
- High permissible circumferential speed.

Application

Rolling mills, large gearboxes.

Material

Sealing lip	Static part	Steel strip	Tension spring
80 NBR B241	85 NBR B247	ST 1.4310	ST 1.4571
75 HNBR U467	85 HNBR 10040	ST 1.4310	ST 1.4571
80 FKM K670	90 FKM K683	ST 1.4310	ST 1.4571

Operating conditions

Material	80 NBR B241	75 HNBR U467	80 FKM K670
	Temperature range in °C		
Mineral oils	-30 ... +100	-20 ... +120	-10 ... +150
Water	+5 ... +100	+5 ... +100	+5 ... +80
Lubricating greases	-30 ... +100	-20 ... +120	-10 ... +150
Rolling oil emulsion	on enquiry		
Pressure p in MPa	0,02		
Running speed v in m/s	25	30	35

Other media on enquiry. Application parameters are recommended values, do not utilise all parameters simultaneously.

Surface quality

Peak-to-valley heights	R _a	R _{max}
Running surface	0,15 ... 0,3 µm	≤2,5 µm
Housing	≤4,0 µm	≤15,0 µm

The contact area is machined by plunge grinding, i.e. without feed. The surface hardness must be approx. 60 HRC (depth of hardening min. 0,5 mm). With increasing circumferential speed the contact area should be manufactured with increasing peak-to-valley heights R_a. The surface should not be too smooth so that an adequate film of lubricant can form. Recommended value: R_{a min} = 0,1 µm. Percentage contact area M_p >50% to max. 90% at cutting depth c = Rz/2 and reference line C ref = 0%. Abrasive surfaces, ridges, scratches and blow-holes are to be avoided.

Design notes

The permissible shaft offset (static eccentricity, centre offset) is dependent on the shaft diameter.

Shaft Ø d	Permissible shaft offset
200 ... 320	2,0 mm
>320 ... 450	2,5 mm
>450	3,0 mm

The permissible shaft offset (dynamic eccentricity) is dependent on the seal profile and the circumferential speed. Please request recommended values.

Lead-in chamfer

See dimension "C" in the housing recommendations for new designs.

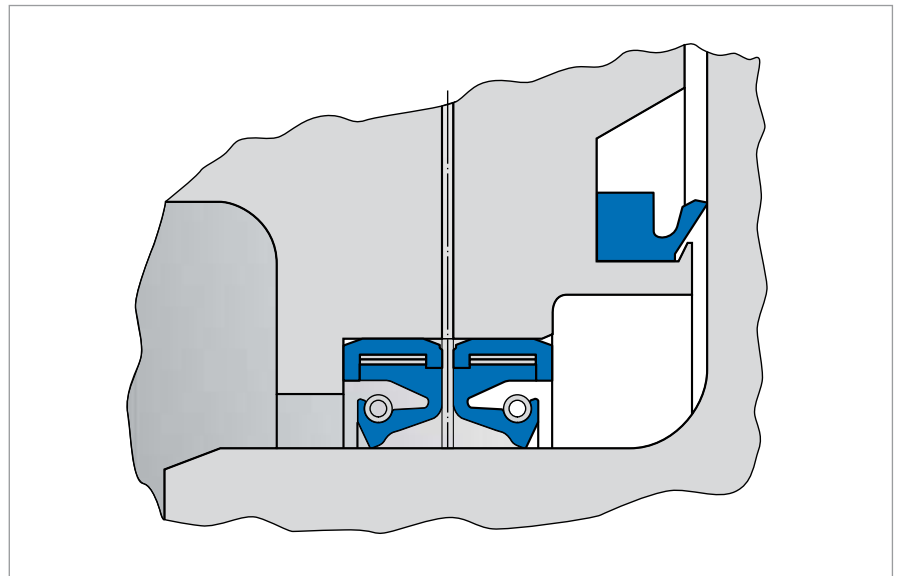
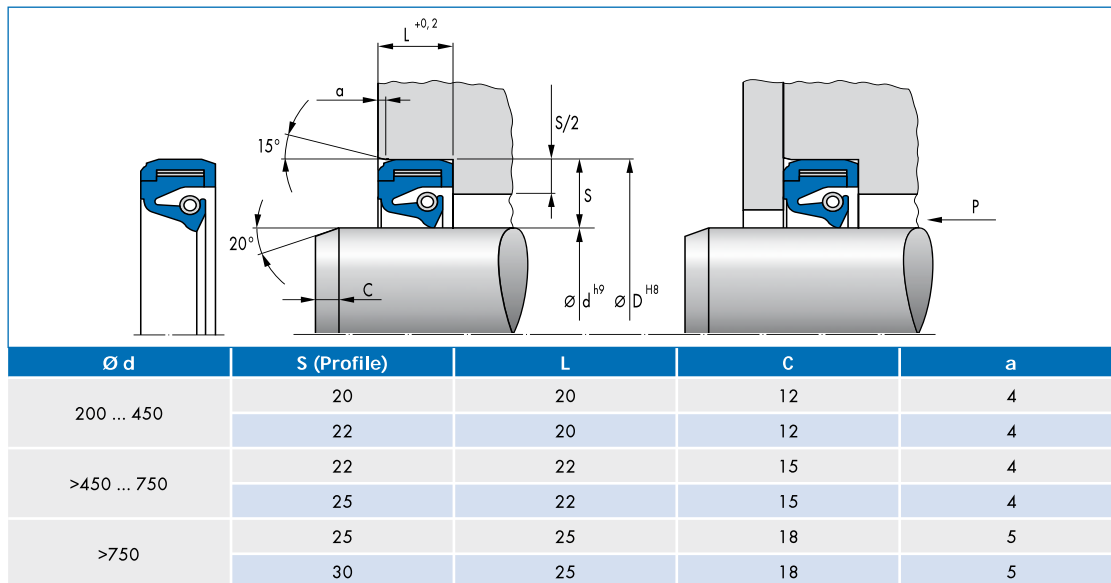

Fig. 2 Typical seal arrangement

Fitting & installation

An axially accessible housing is necessary for the fitting of the Simmerring Radiamatic RHS 51. Only endless self-holding Simmerrings Radiamatic RHS 51 are available.

Housing recommendations for new designs



Simmerring Modular Sealing Component (MSC 01, MSC 02)

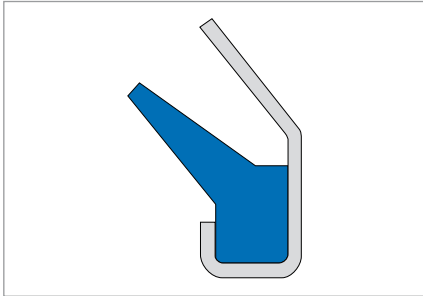

Fig. 1 Simmerring MSC 01

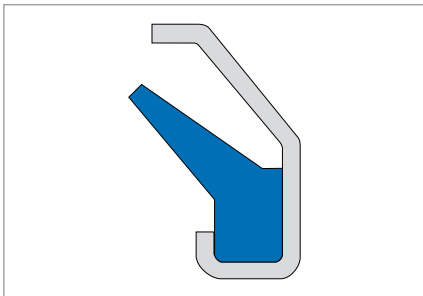

Fig. 2 Simmerring MSC 02

Product description

- Outer casing: metal housing
- Dust lip without spring.

Product advantages

- Simple proven sealing component for secondary applications
- As a seal against grease
- As additional seal against moderate to medium dust and dirt ingress
- Can be used as part of the Simmerring Modular Sealing Solution (MSS).

Application

- Power tools
- Industrial gearboxes
- Pumps.

Material

Acrylonitrile-butadiene rubber

Code	80 NBR 177458
Colour	Black
Hardness	80 Shore A

Fluoro elastomer

Code	80 FKM 177459
Colour	Red brown
Hardness	80 Shore A

Metal housing	Yellow chromated, deep-drawn steel sheet as corrosion protection.
---------------	---

Alternatively in stainless steel on enquiry

Operating conditions

Media	Greases
T	-40 ... +100 °C (NBR) -25 ... +160 °C (FKM)
v	to 6 m/s

Max. permissible values depend on the other operating conditions.

Fitting & installation

Shaft

Tolerance	ISO h 9
Runout	IT 8
Roughness	$R_z = 1,0 \dots 5,0 \mu\text{m}$
	$R_{\text{max}} = <6,3 \mu\text{m}$

Range of dimensions for shafts- $\varnothing D_1$

Simmerring MSC 01	10 ... 135 mm
Simmerring MSC 02	15 ... 100 mm

→ Technical Manual.

Article list

d ₁	d ₂	b	Outer surface	Pressure	Material	Type	Article No.	
10	24	3,5	metal	un-pressurised	80 NBR 177458	MSC 01	508511	●
10	24	3,5	metal	un-pressurised	80 FKM 177459	MSC 01	508559	●
11	26	3,5	metal	un-pressurised	80 NBR 177458	MSC 01	508512	●
11	26	3,5	metal	un-pressurised	80 FKM 177459	MSC 01	508560	●
12	26	3,5	metal	un-pressurised	80 NBR 177458	MSC 01	508513	●
12	26	3,5	metal	un-pressurised	80 FKM 177459	MSC 01	508561	●
14	30	4	metal	un-pressurised	80 NBR 177458	MSC 01	508514	●
14	30	4	metal	un-pressurised	80 FKM 177459	MSC 01	508562	●
15	30	4	metal	un-pressurised	80 NBR 177458	MSC 01	508515	●
15	30	4	metal	un-pressurised	80 FKM 177459	MSC 01	508563	●
15	32	6	metal	un-pressurised	80 FKM 177459	MSC 02	508604	●
15	32	6	metal	un-pressurised	80 NBR 177458	MSC 02	508628	●
16	32	4	metal	un-pressurised	80 NBR 177458	MSC 01	508516	●
16	32	4	metal	un-pressurised	80 FKM 177459	MSC 01	508564	●
17	32	4	metal	un-pressurised	80 NBR 177458	MSC 01	508517	●
17	32	4	metal	un-pressurised	80 FKM 177459	MSC 01	508565	●
17	34	6	metal	un-pressurised	80 FKM 177459	MSC 02	508605	●
17	34	6	metal	un-pressurised	80 NBR 177458	MSC 02	508629	●
18	33	4	metal	un-pressurised	80 NBR 177458	MSC 01	508518	●
18	33	4	metal	un-pressurised	80 FKM 177459	MSC 01	508566	●
20	35	4	metal	un-pressurised	80 NBR 177458	MSC 01	508519	●
20	35	4	metal	un-pressurised	80 FKM 177459	MSC 01	508567	●
20	37	6	metal	un-pressurised	80 FKM 177459	MSC 02	508606	●
20	37	6	metal	un-pressurised	80 NBR 177458	MSC 02	508630	●
22	40	4	metal	un-pressurised	80 NBR 177458	MSC 01	508520	●
22	40	4	metal	un-pressurised	80 FKM 177459	MSC 01	508568	●
24	40	4	metal	un-pressurised	80 NBR 177458	MSC 01	508521	●
24	40	4	metal	un-pressurised	80 FKM 177459	MSC 01	508569	●
25	40	4	metal	un-pressurised	80 NBR 177458	MSC 01	508522	●
25	40	4	metal	un-pressurised	80 FKM 177459	MSC 01	508571	●
25	42	6	metal	un-pressurised	80 FKM 177459	MSC 02	508607	●
25	42	6	metal	un-pressurised	80 NBR 177458	MSC 02	508631	●
26	40	4	metal	un-pressurised	80 NBR 177458	MSC 01	508523	●
26	40	4	metal	un-pressurised	80 FKM 177459	MSC 01	508572	●
28	43	4	metal	un-pressurised	80 NBR 177458	MSC 01	508524	●
28	43	4	metal	un-pressurised	80 FKM 177459	MSC 01	508573	●
30	47	4,5	metal	un-pressurised	80 NBR 177458	MSC 01	508525	●
30	47	4,5	metal	un-pressurised	80 FKM 177459	MSC 01	508574	●
30	48	6,5	metal	un-pressurised	80 FKM 177459	MSC 02	508608	●
30	48	6,5	metal	un-pressurised	80 NBR 177458	MSC 02	508632	●
32	49	4,5	metal	un-pressurised	80 NBR 177458	MSC 01	508527	●
32	49	4,5	metal	un-pressurised	80 FKM 177459	MSC 01	508575	●
35	52	4,5	metal	un-pressurised	80 NBR 177458	MSC 01	508528	●
35	52	4,5	metal	un-pressurised	80 FKM 177459	MSC 01	508576	●
35	53	6,5	metal	un-pressurised	80 FKM 177459	MSC 02	508609	●
35	53	6,5	metal	un-pressurised	80 NBR 177458	MSC 02	508633	●
38	55	4,5	metal	un-pressurised	80 NBR 177458	MSC 01	508529	●
38	55	4,5	metal	un-pressurised	80 FKM 177459	MSC 01	508577	●
40	57	4,5	metal	un-pressurised	80 NBR 177458	MSC 01	508530	●

● Available from stock ○ On request: Tool is available, delivery at short notice

d ₁	d ₂	b	Outer surface	Pressure	Material	Type	Article No.	
40	57	4,5	metal	un-pressurised	80 FKM 177459	MSC 01	508578	●
40	58	6,5	metal	un-pressurised	80 FKM 177459	MSC 02	508610	●
40	58	6,5	metal	un-pressurised	80 NBR 177458	MSC 02	508634	●
41	57	4,5	metal	un-pressurised	80 NBR 177458	MSC 01	508531	●
41	57	4,5	metal	un-pressurised	80 FKM 177459	MSC 01	508579	●
42	59	4,5	metal	un-pressurised	80 NBR 177458	MSC 01	508532	●
42	59	4,5	metal	un-pressurised	80 FKM 177459	MSC 01	508580	●
45	62	4,5	metal	un-pressurised	80 NBR 177458	MSC 01	508533	●
45	62	4,5	metal	un-pressurised	80 FKM 177459	MSC 01	508581	●
45	63	6,5	metal	un-pressurised	80 FKM 177459	MSC 02	508611	●
45	63	6,5	metal	un-pressurised	80 NBR 177458	MSC 02	508635	●
48	65	4,5	metal	un-pressurised	80 NBR 177458	MSC 01	508534	●
48	65	4,5	metal	un-pressurised	80 FKM 177459	MSC 01	508583	●
50	70	5,5	metal	un-pressurised	80 NBR 177458	MSC 01	508535	●
50	70	5,5	metal	un-pressurised	80 FKM 177459	MSC 01	508584	●
50	72	7,5	metal	un-pressurised	80 FKM 177459	MSC 02	508612	●
50	72	7,5	metal	un-pressurised	80 NBR 177458	MSC 02	508636	●
52	72	5,5	metal	un-pressurised	80 NBR 177458	MSC 01	508536	●
52	72	5,5	metal	un-pressurised	80 FKM 177459	MSC 01	508585	●
55	75	5,5	metal	un-pressurised	80 NBR 177458	MSC 01	508537	●
55	75	5,5	metal	un-pressurised	80 FKM 177459	MSC 01	508586	●
55	77	7,5	metal	un-pressurised	80 FKM 177459	MSC 02	508613	●
55	77	7,5	metal	un-pressurised	80 NBR 177458	MSC 02	508637	●
58	78	5,5	metal	un-pressurised	80 NBR 177458	MSC 01	508539	●
58	78	5,5	metal	un-pressurised	80 FKM 177459	MSC 01	508587	●
60	80	5,5	metal	un-pressurised	80 NBR 177458	MSC 01	508540	●
60	80	5,5	metal	un-pressurised	80 FKM 177459	MSC 01	508588	●
60	82	7,5	metal	un-pressurised	80 FKM 177459	MSC 02	508614	●
60	82	7,5	metal	un-pressurised	80 NBR 177458	MSC 02	508638	●
62	82	5,5	metal	un-pressurised	80 NBR 177458	MSC 01	508544	●
62	82	5,5	metal	un-pressurised	80 FKM 177459	MSC 01	508589	●
65	85	5,5	metal	un-pressurised	80 NBR 177458	MSC 01	508546	●
65	85	5,5	metal	un-pressurised	80 FKM 177459	MSC 01	508590	●
65	87	7,5	metal	un-pressurised	80 FKM 177459	MSC 02	508615	●
65	87	7,5	metal	un-pressurised	80 NBR 177458	MSC 02	508639	●
68	88	5,5	metal	un-pressurised	80 NBR 177458	MSC 01	508547	●
68	88	5,5	metal	un-pressurised	80 FKM 177459	MSC 01	508591	●
70	90	5,5	metal	un-pressurised	80 NBR 177458	MSC 01	508548	●
70	90	5,5	metal	un-pressurised	80 FKM 177459	MSC 01	508592	●
70	92	7,5	metal	un-pressurised	80 FKM 177459	MSC 02	508616	●
70	92	7,5	metal	un-pressurised	80 NBR 177458	MSC 02	508640	●
72	92	5,5	metal	un-pressurised	80 NBR 177458	MSC 01	508549	●
72	92	5,5	metal	un-pressurised	80 FKM 177459	MSC 01	508593	●
75	95	5,5	metal	un-pressurised	80 NBR 177458	MSC 01	508550	●
75	95	5,5	metal	un-pressurised	80 FKM 177459	MSC 01	508594	●
75	97	7,5	metal	un-pressurised	80 FKM 177459	MSC 02	508617	●
75	97	7,5	metal	un-pressurised	80 NBR 177458	MSC 02	508641	●
78	98	5,5	metal	un-pressurised	80 NBR 177458	MSC 01	508551	●
78	98	5,5	metal	un-pressurised	80 FKM 177459	MSC 01	508595	●
80	100	5,5	metal	un-pressurised	80 NBR 177458	MSC 01	508552	●

● Available from stock ○ On request: Tool is available, delivery at short notice

d ₁	d ₂	b	Outer surface	Pressure	Material	Type	Article No.	
80	100	5,5	metal	un-pressurised	80 FKM 177459	MSC 01	508597	●
80	102	7,5	metal	un-pressurised	80 FKM 177459	MSC 02	508618	●
80	102	7,5	metal	un-pressurised	80 NBR 177458	MSC 02	508642	●
85	105	5,5	metal	un-pressurised	80 NBR 177458	MSC 01	508553	●
85	105	5,5	metal	un-pressurised	80 FKM 177459	MSC 01	508598	●
85	107	7,5	metal	un-pressurised	80 FKM 177459	MSC 02	508619	●
85	107	7,5	metal	un-pressurised	80 NBR 177458	MSC 02	508643	●
90	110	5,5	metal	un-pressurised	80 NBR 177458	MSC 01	508554	●
90	110	5,5	metal	un-pressurised	80 FKM 177459	MSC 01	508599	●
90	112	7,5	metal	un-pressurised	80 FKM 177459	MSC 02	508620	●
90	112	7,5	metal	un-pressurised	80 NBR 177458	MSC 02	508644	●
95	115	5,5	metal	un-pressurised	80 NBR 177458	MSC 01	508555	●
95	115	5,5	metal	un-pressurised	80 FKM 177459	MSC 01	508600	●
95	117	7,5	metal	un-pressurised	80 FKM 177459	MSC 02	508621	●
95	117	7,5	metal	un-pressurised	80 NBR 177458	MSC 02	508645	●
100	120	5,5	metal	un-pressurised	80 NBR 177458	MSC 01	508556	●
100	120	5,5	metal	un-pressurised	80 FKM 177459	MSC 01	508601	●
100	122	7,5	metal	un-pressurised	80 FKM 177459	MSC 02	508622	●
100	122	7,5	metal	un-pressurised	80 NBR 177458	MSC 02	508646	●
105	125	5,5	metal	un-pressurised	80 NBR 177458	MSC 01	508557	●
105	125	5,5	metal	un-pressurised	80 FKM 177459	MSC 01	508602	●
135	159	6,5	metal	un-pressurised	80 NBR 177458	MSC 01	508558	●
135	159	6,5	metal	un-pressurised	80 FKM 177459	MSC 01	508603	●

● Available from stock ○ On request: Tool is available, delivery at short notice

Simmerring Modular Sealing Solution 1 (MSS 1)

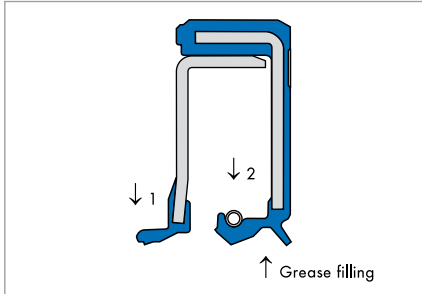

Fig. 1 Simmerring MSS 1 NBR/FKM

Product description

- Outer casing: elastomer (smooth)
- Spring-loaded sealing lip and sealing lip with helix edge without spring
- Additional dust lip
- Modern sealing lip profile
- Friction-optimised primary seal lip 1 made from fluoro rubber 75 FKM 585
- Secondary seal lip with additional dust lip 2
- Grease filling with special lubricant Klüber Petamo GHY 133 N.

Product advantages

- Broad range of applications, for example in industrial gearboxes
- Reliable sealing of the housing bore, even with increased roughness of the bore, thermal expansion and split housings, thus a sealing of low viscosity and gaseous media is also possible
- Very long service life and reliability, especially when subject to strong external dirt and/or contamination (metal abrasion, cast sand) of the lubricant
- Optimal for vertical unit application
- Very narrow axial design
- Reliable sealing of the housing bore etc.

Application

- Industrial gearboxes.

Material

Acrylonitrile-butadiene rubber/Fluoro elastomer

Code	72 NBR 902/75 FKM 585
Hardness	72 Shore A/75 Shore A

Fluoro elastomer/Fluoro elastomer

Code	75 FKM 585/75 FKM 585
Hardness	75 Shore A/75 Shore A

Metal insert	Unalloyed steel DIN EN 10027-1
Spring	Spring steel DIN EN 10270-1

Operating conditions

Materials combination	NBR/FKM	FKM/FKM
T	-25 ... +100 °C	-25 ... +160 °C
v	0 ... 6 m/s	0 ... 6 m/s
p	0 ... 0,05 MPa/0,5 bar	0 ... 0,05 MPa/0,5 bar

Max. permissible values depend on the other operating conditions.

Fitting & installation

Shaft

Tolerance	ISO h 11
Runout	IT 8
Roughness	$R_a = 0,2 \dots 0,8 \mu\text{m}$
	$R_z = 1,0 \dots 5,0 \mu\text{m}$
	$R_{max} = <6,3 \mu\text{m}$
Hardness	45 ... 60 HRC
Finish	No lead; preferably plunge ground

Housing bore

Tolerance	ISO H8
Roughness	$R_z = 10 \dots 25 \mu\text{m}$

Careful fitting according to DIN 3760 is a prerequisite for the correct function of the seal → Technical Manual.

Range of dimensions for shafts-Ø d₁

Simmerring MSS 1	35 ... 145 mm
------------------	---------------

Artikelliste

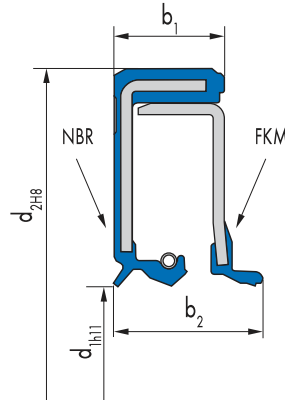

d ₁	d ₂	b ₁	b ₂	Outer surface	Pressure	Material	Article No.	
20	42	6	8	smooth	0,05	75 FKM 585	527075	●
20	52	6	8	smooth	0,05	75 FKM 585	531002	●
25	47	10	13,5	smooth	0,05	75 FKM 585	527074	●
30	52	6	8	smooth	0,05	72 NBR 902	528998	●
30	52	6	8	smooth	0,05	75 FKM 585	49011594	●
35	62	8	10	smooth	0,05	72 NBR 902	525414	●
35	62	8	10	smooth	0,05	75 FKM 585	525445	●
40	68	10		smooth	0,05	72 NBR 902	49028784	●
40	80	10	13,5	smooth	0,05	72 NBR 902	525350	●
45	75	8	10	smooth	0,05	72 NBR 902	49005160	●
45	85	10	13,5	smooth	0,05	72 NBR 902	525382	●
47	65	10	13,5	smooth	0,05	72 NBR 902	525416	●
47	90	10	13,5	smooth	0,05	72 NBR 902	525417	●
50	65	10	13,5	smooth	0,05	72 NBR 902	525357	●
50	80	10	13,5	smooth	0,05	72 NBR 902	525353	●
50	90	10	13,5	smooth	0,05	72 NBR 902	525358	●
52	72	10	13,5	smooth	0,05	72 NBR 902	525379	●
52	100	10	13,5	smooth	0,05	72 NBR 902	525389	●
55	72	10	13,5	smooth	0,05	72 NBR 902	525360	●
55	72	10	13,5	smooth	0,05	75 FKM 585	525365	●
55	90	10	13,5	smooth	0,05	72 NBR 902	525359	●
55	90	10	13,5	smooth	0,05	75 FKM 585	525364	○
55	100	10	13,5	smooth	0,05	72 NBR 902	525393	●
55	100	10	13,5	smooth	0,05	75 FKM 585	525425	○
60	110	12	16,5	smooth	0,05	72 NBR 902	525366	●
60	110	12	16,5	smooth	0,05	75 FKM 585	525369	●
62	90	12	16,5	smooth	0,05	72 NBR 902	525384	●
62	90	12	16,5	smooth	0,05	75 FKM 585	525422	●
62	120	12	16,5	smooth	0,05	72 NBR 902	525400	●
65	85	12	16,5	smooth	0,05	72 NBR 902	525383	●
65	100	12	16,5	smooth	0,05	72 NBR 902	525394	●
65	100	12	16,5	smooth	0,05	75 FKM 585	525426	●
65	120	12	16,5	smooth	0,05	72 NBR 902	525367	●
65	120	12	16,5	smooth	0,05	75 FKM 585	525370	●
65	140	12	16,5	smooth	0,05	72 NBR 902	525368	●

● Available from stock ○ On request: Tool is available, delivery at short notice

d ₁	d ₂	b ₁	b ₂	Outer surface	Pressure	Material	Article No.	
70	90	12	16,5	smooth	0,05	72 NBR 902	525376	●
70	110	12	16,5	smooth	0,05	72 NBR 902	525375	●
72	95	12	16,5	smooth	0,05	72 NBR 902	525386	●
72	95	12	16,5	smooth	0,05	75 FKM 585	525423	●
72	140	12	16,5	smooth	0,05	72 NBR 902	525403	●
72	140	12	16,5	smooth	0,05	75 FKM 585	525432	●
75	130	12	16,5	smooth	0,05	72 NBR 902	525377	●
80	100	12	16,5	smooth	0,05	72 NBR 902	525395	●
80	100	12	16,5	smooth	0,05	75 FKM 585	525427	●
80	125	12	16,5	smooth	0,05	72 NBR 902	525402	●
82	120	13	19,5	smooth	0,05	72 NBR 902	525401	●
82	160	13	19,5	smooth	0,05	72 NBR 902	525407	●
82	160	13	19,5	smooth	0,05	75 FKM 585	525437	○
85	110	12	18,5	smooth	0,05	72 NBR 902	525387	●
85	140	12	18,5	smooth	0,05	72 NBR 902	525385	●
85	140	12	18,5	smooth	0,05	75 FKM 585	525390	●
95	125	13	19,5	smooth	0,05	72 NBR 902	525397	●
95	145	13	19,5	smooth	0,05	72 NBR 902	525405	●
95	145	13	19,5	smooth	0,05	75 FKM 585	525434	○
95	170	13	19,5	smooth	0,05	72 NBR 902	525396	○
108	170	15	22,5	smooth	0,05	72 NBR 902	525409	●
120	150	15	22,5	smooth	0,05	72 NBR 902	525406	●
120	150	15	22,5	smooth	0,05	75 FKM 585	525435	●
125	160	15	22,5	smooth	0,05	72 NBR 902	525408	●
125	200	15	22,5	smooth	0,05	72 NBR 902	525412	●
145	230	17	25,5	smooth	0,05	72 NBR 902	525413	●
145	230	17	25,5	smooth	0,05	75 FKM 585	525444	○

● Available from stock ○ On request: Tool is available, delivery at short notice

Simmerring Modular Sealing Solution 1+ (MSS 1+ Condition Monitoring)

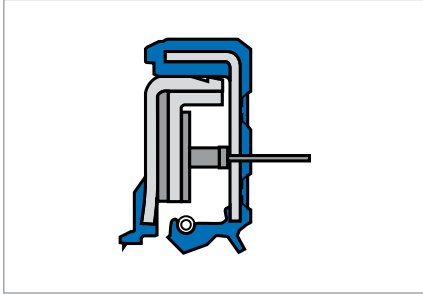

Fig. 1 Simmerring Modular Sealing Solution 1+ (MSS 1+ Condition Monitoring)

Product description

Modification of the standard MSS 1 design with additional function for detection of early leakage.
 Additional function: Optical sensor and special fleece leakage collector with evaluation electronics for transmission and interpretation of the signals.

Product advantages

- Simmerring MSS 1+ CM features:
- Reliable warning of leakage
 - Maintenance intervals can be planned
 - Cost-effective small volume series, no tool costs
 - Media-specific adaptation of the evaluation electronics.

Application

Industrial gearboxes, drive shafts, pumps and other conceivable application areas.

Material

Acrylonitrile-butadiene rubber/Fluoro elastomer

Code	72 NBR 902/75 FKM 585
Hardness	72 Shore A/75 Shore A
Sensor	Sensor, ribbon cable

Operating conditions

Materials combination	NBR/FKM
T	-25 ... +100 °C
v	0 ... 6 m/s
P	0 ... 0,05 MPa/0,5 bar

Max. permissible values depend on the other operating conditions.

Design notes

Limited range of sizes, larger Simmerrings may be equipped with several sensors.

Simmerring Modular Sealing Solution 7 (MSS 7)

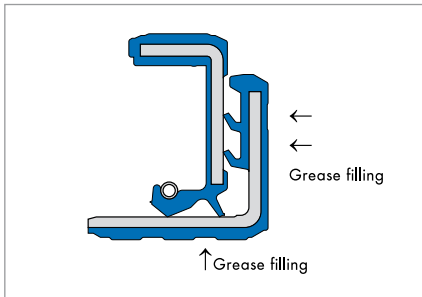

Fig. 1 Simmerring MSS 7

Product description

- Outer casing: elastomer
- Spring-loaded sealing lip
- Additional dust lips
- Modern sealing lip profile
- High resistance to dirt ingress
- Robust solution
- Grease between the sealing lip and dust lip with special lubricant Klüber Petamo GHY 133 N.

Product advantages

- Broad range of applications
- Reliable sealing of the housing bore, even with increased roughness of the bore, thermal expansion and split housings, thus a sealing of low viscosity and gaseous media also possible
- Additional axial dust lip(s) against moderate to medium dust and dirt ingress from outside.

Application

- Sealing of special gearboxes (e.g. automated washing system/ car wash)
- Axles for agricultural and construction machinery, axles for special vehicles.

Material

Acrylonitrile-butadiene rubber

Code	72 NBR 902
Hardness	72 Shore A
Metal insert	Unalloyed steel DIN EN 10027-1
Spring	Spring steel DIN EN 10270-1

Material 75 FKM 585 on enquiry.

Operating conditions

Material	72 NBR 902
T	<80 °C
v	0 ... 5 m/s
p	0 ... 0,05 MPa/0,5 bar

Max. permissible values depend on the other operating conditions.

Fitting & installation

Shaft

Tolerance	ISO h8
Runout:	IT 8
Roughness	R _z = 10 ... 16 µm

Housing bore

Tolerance	ISO H8
Roughness	R _z = 10 ... 16 µm

Careful fitting according to DIN 3760 is a prerequisite for the correct function of the seal → Technical Manual.

Range of dimensions for shafts-Ø d₁

Simmerring MSS 7	35 ... 150 mm
-------------------------	---------------

Article list

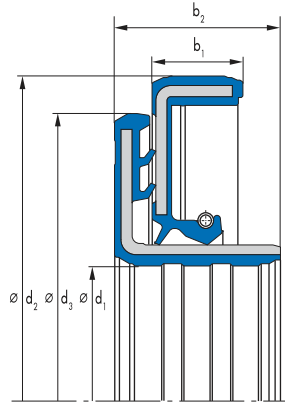

d_1	d_2	d_3	b_1	b_2	Outer surface	Pressure	Material	Article No.	
35	62	56	8	14	smooth	0,05	72 NBR 902	477277	●
45	75	68	7	12,5	smooth	0,05	72 NBR 902	522352	●
45	80	73	8	15	smooth	0,05	72 NBR 902	522353	●
55	90	83	9	17	smooth	0,05	72 NBR 902	522351	●
60	110	98	10	18	smooth	0,05	72 NBR 902	477237	●
65	100	90	10	18	smooth	0,05	72 NBR 902	522350	●
70	130	110	10	17	smooth	0,05	72 NBR 902	522285	●
80	125	113	10	19	smooth	0,05	72 NBR 902	522349	●
80	150	120	12	22	smooth	0,05	72 NBR 902	522286	●
95	145	135	12	22	smooth	0,05	72 NBR 902	522348	●
100	190	140	12	22	smooth	0,05	72 NBR 902	522305	●
110	170	150	12	22	smooth	0,05	72 NBR 902	522347	●
110	215	150	12	24	smooth	0,05	72 NBR 902	522308	●
120	180	160	12	24	smooth	0,05	72 NBR 902	522346	●
130	215	170	12	24	smooth	0,05	72 NBR 902	522311	●
150	225	190	12	24	smooth	0,05	72 NBR 902	522345	●

● Available from stock ○ On request: Tool is available, delivery at short notice

Simmerring Cassette Seal Type 1



Fig.1 Simmerring Cassette Seal Type 1

Application

These examples of use provide general information on the primary applications for Simmerring Cassette Seals and their performance in relation to dirt from the outside. Simmerring Cassette Seals (types 1, 2 or 3) must be selected taking into account the application conditions (shaft speed, oil temperature, etc.).

- Agricultural machinery (tractors)
 - Axles: pinions
- Construction machinery (road rollers, excavators, fork-lift trucks, mixers)
 - Axles: pinions
 - Power take-off drives
- Commercial vehicles (lorries, busses, trailers, special vehicles)
 - Axles: hubs
 - Axles: propeller shafts*
 - Axles: pinions.

* With axial shaft movement, special design necessary.

Product description

- Design: special types, on enquiry
- Outer casing: elastomer/sheet metal
- Spring-loaded sealing lip
- Additional dust lips
- high resistance to dirt ingress
- Robust solution.

Product advantages

- Lengthening of maintenance interval for individual units
- Shaft must not be hardened or ground
- Old solution can usually be replaced by Simmerring Cassette Seal without change to housing
- The shaft must not be machined on maintenance or seal replacement.

Material

Acrylonitrile-butadiene rubber

Code	75 NBR 106200
Colour	Black

Fluoro elastomer

Code	75 FKM 595
Colour	Red brown

Metal insert	Unalloyed steel DIN 1624 – EN10139
Spring	Spring steel 17223

Operating conditions

Materials combination	75 NBR 106200	75 FKM 595
T	<80 °C	<100 °C
v	to 7 m/s	to 9 m/s
p	max. 0,05 MPa/0,5 bar	max. 0,05 MPa/0,5 bar

For material definitions, it must be taken into account that it is possible that not all extreme conditions will occur simultaneously.

Fitting & installation

Shaft

Tolerance	ISO h8
Runout	IT 8
Roughness	R _z = 10 ... 16 µm

Housing bore

Tolerance	ISO H8
Roughness	R _z = 10 ... 16 µm

Careful fitting according to DIN 3760 is a prerequisite for the correct function of the seal → Technical Manual.

Further information on enquiry.

Range of dimensions for shafts-Ø D₁

Simmerring Cassette Seal type 1	55 ... 133,35 mm
---------------------------------	------------------

Article list

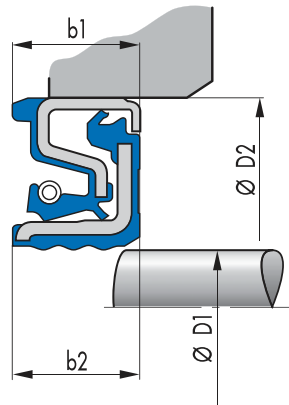

D_1	D_2	b_1	b_2	Material	Article No.	
55	80	12,5	14	75 FKM 595	12016792	<input type="radio"/>

● Available from stock ○ On request: Tool is available, delivery at short notice

Simmerring Cassette Seal Type 2

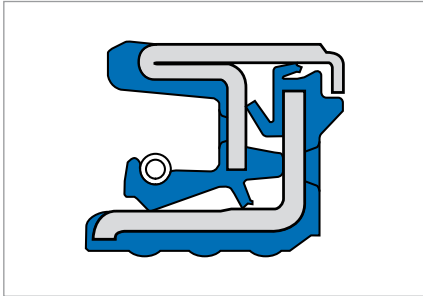

Fig.1 Simmerring Cassette Seal Type 2

Application

These examples of use provide general information on the primary applications for Simmerring Cassette Seals and their performance in relation to dirt from the outside. Simmerring Cassette Seals (types 1, 2 or 3) must be selected taking into account the application conditions (shaft speed, oil temperature, etc.).

Further information on enquiry.

- Agricultural machinery
 - Tedders
 - Sewing machinery
 - Pricking out machinery
 - Combine harvesters
 - Threshing machinery.

Product description

- Design: special types, on enquiry
- Outer casing: elastomer/sheet metal
- Spring-loaded sealing lip
- Additional dust lips
- High resistance to dirt ingress
- Robust solution.

Product advantages

- Lengthening of maintenance interval for individual units
- Shaft must not be hardened or ground
- Old solution can usually be replaced by Simmerring Cassette Seal without change to housing
- The shaft must not be machined on maintenance or seal replacement.

Material

Acrylonitrile-butadiene rubber

Code	75 NBR 106200
Colour	Black

Fluoro elastomer

Code	75 FKM 595
Colour	Red brown

Metal insert	Unalloyed steel DIN 1624 – EN10139
Spring	Spring steel 17223

Operating conditions

Materials combination	75 NBR 106200	75 FKM 595
T	<80 °C	<100 °C
v	to 5 m/s	to 7 m/s
p	max. 0,05 MPa/0,5 bar	max. 0,05 MPa/0,5 bar

For material definitions, it must be taken into account that it is possible that not all extreme conditions will occur simultaneously.

Fitting & installation

Shaft

Tolerance	ISO h8
Runout	IT 8
Roughness	R _z = 10 ... 16 µm

Housing bore

Tolerance	ISO H8
Roughness	R _z = 10 ... 16 µm

Careful fitting according to DIN 3760 is a prerequisite for the correct function of the seal → Technical Manual .

Further information on enquiry.

Range of dimensions for shafts-Ø D₁

Simmerring Cassette Seal type 2	35 ... 190 mm
---------------------------------	---------------

Article list

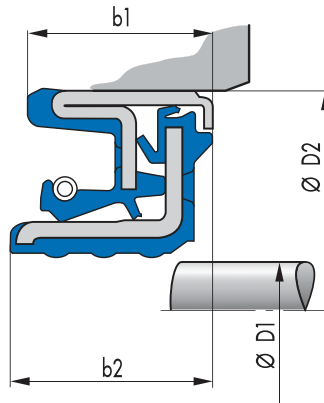

D ₁	D ₂	b ₁	b ₂	Material	Article No.	
65	92	10	15	75 FKM 585	12018849	○
65	105	13	14,5	75 NBR 106200	12018825	○
75	100	13	14,5	75 NBR 106200	12019088	○
80	100	12	13,7	75 NBR 106200	12019145	○
85	115	12		75 NBR 106200	12020003	○
85	115	12		75 FKM 595	12020004	○
95	130	16		75 FKM 585	12020008	○
110	140	14,5	16	75 NBR 106200	12014492	○
110	140	14,5	16	75 FKM 595	12014899	○
111	146	13,5	14,5	75 NBR 106200	12017210	○
155	190	14,5	16	75 FKM 595	12020173	○
155	190	17,5	19	75 FKM 595	12014851	○
165	190	15,5	17	75 NBR 106200	12015133	○
165	190	15,5	17	75 NBR 106200	12019501	○
190	215	15,5	17	75 NBR 106200	12016896	○

● Available from stock ○ On request: Tool is available, delivery at short notice

Simmerring Cassette Seal Type 3

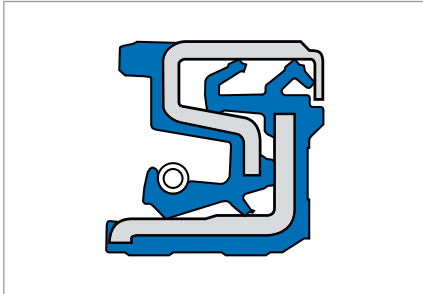

Fig.1 Simmerring Cassette Seal Type 3

Product description

- Design: special types, on enquiry
- Outer casing: elastomer/sheet metal
- Spring-loaded sealing lip
- Additional dust lips
- High resistance to dirt ingress
- Robust solution.

Product advantages

- Lengthening of maintenance interval for individual units
- Shaft must not be hardened or ground
- Old solution can usually be replaced by Simmerring Cassette Seal without change to housing
- The shaft must not be machined on maintenance or seal replacement.

Application

These examples of use provide general information on the primary applications for Simmerring Cassette Seals and their performance in relation to dirt from the outside. Simmerring Cassette Seals (types 1, 2 or 3) must be selected taking into account the application conditions (shaft speed, oil temperature, etc.). Further information on enquiry.

- Agricultural machinery
 - Tractors/hub
 - Tractors/propeller shafts*
 - Harrows
 - Motorised cultivators
 - Tillers
 - Fertiliser spreading machinery
- Construction machinery (road rollers, excavators, fork-lift trucks, mixers)
 - Axles: hubs
 - Axles: propeller shafts*.

* With axial shaft movement, special design necessary.

Material

Acrylonitrile-butadiene rubber

Code	75 NBR 106200
Colour	Black

Fluoro elastomer

Code	75 FKM 595
Colour	Red brown

Metal insert	Unalloyed steel DIN 1624 – EN10139
Spring	Spring steel 17223

Operating conditions

Materials combination	75 NBR 106200	75 FKM 595
T	<80 °C	<100 °C
v	to 4 m/s	to 6 m/s
p	max. 0,05 MPa/0,5 bar	max. 0.05 MPa/0.5 bar

For material definitions, it must be taken into account that it is possible that not all extreme conditions will occur simultaneously.

Fitting & installation

Shaft

Tolerance	ISO h8
Runout	IT 8
Roughness	R _z = 10 ... 16 µm

Housing bore

Tolerance	ISO H8
Roughness	R _z = 10 ... 16 µm

Careful fitting according to DIN 3760 is a prerequisite for the correct function of the seal → Technical Manual.

Further information on enquiry.

Range of dimensions for shafts-Ø D₁

Simmerring Cassette Seal type 3	25 ... 210 mm
---------------------------------	---------------

Article list

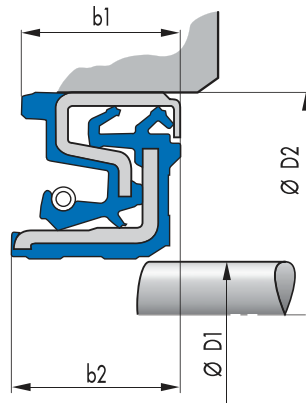

D_1	D_2	b_1	b_2	Material	Article No.	
25	52	12		75 NBR 106200	12015223	○
35	60	13	14,5	75 NBR 106200	12017029	○
35	62	13,5	14	75 FKM 585	12019335	○
35	65	14,5	17	75 NBR 106200	12019775	○
45	70	14	17	75 NBR 106200	12015392	○
45	70	14	17	75 FKM 595	12016630	○
48	75	14	17	75 NBR 106200	12015395	○
56	80	13	14,5	75 FKM 595	12016694	○
56	80	13	14,5	75 NBR 106200	12018036	○
60	84	13	14,5	75 FKM 585	12019351	○
60	84	13	14,5	75 NBR 106200	12019352	○
60	90	13,5	15	75 FKM 595	12016418	○
60	90	13,5	15	75 NBR 106200	12016423	○
65	90	13	14,5	75 NBR 106200	12019533	○
70	95	13	14,5	75 NBR 106200	12018338	○
70	95	13	14,5	75 FKM 585	12019199	○
75	100	13	14,5	75 FKM 585	12019120	○
85	110	13	14,5	75 NBR 106200	12016635	○
85	110	13	14,5	75 FKM 595	12017093	○
85	140	15	17	75 NBR 106200	12019153	○
100	129,85	12,5	14	75 NBR 106200	12020095	○
110	140	13,5	15,5	75 FKM 595	12019735	○
110	140	13,5	15,5	75 NBR 106200	12019736	○
120	150	14	15,5	75 NBR 106200	12019941	○
120	160	15	17,5	75 NBR 106200	12018572	○
121,8	150	13	12	75 NBR 106200	12020222	○
127	160	15,5	17,5	75 NBR 106200	12019068	○
130	160	14,5	16	75 NBR 106200	12016448	○
130	160	14,5	16	75 FKM 585	12019208	○
140	170	14,5	16	75 NBR 106200	12016688	○
140	170	14,5	16	75 NBR 106200	12019137	○
145	175	14,5	15,5	75 NBR 902	12019116	○
150	180	14,5	16	75 NBR 106200	12018035	○
150	180	14,5	16	75 FKM 595	12019742	○
155	190	17,5	19	75 NBR 106200	12014852	○

● Available from stock ○ On request: Tool is available, delivery at short notice

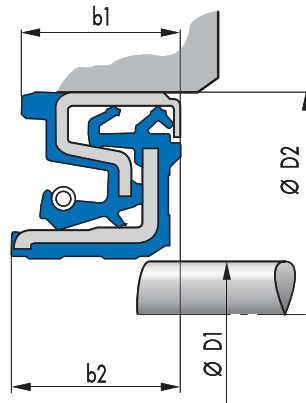

D ₁	D ₂	b ₁	b ₂	Material	Article No.	
155	195	16,5	18	75 NBR 106200	12016391	○
165	195	16,5	18	75 NBR 106200	12015149	○
165	195	16,5	18	75 FKM 595	12018543	○
170	200	15	16	75 NBR 902	12019056	○
170	200	15	16	75 FKM 595	12019084	○
178	208	16	18	75 NBR 106200	12018107	○
178	208	16	18	75 FKM 595	12019737	○
190	220	16	18	75 NBR 106200	12017120	○
190	220	16	18	75 FKM 595	12018658	○
210	240	16	18	75 NBR 106200	12019114	○
220	265	19	21	75 FKM 595	12019741	○
220	265	19	21	75 NBR 106200	12019966	○
235	270	20	22	75 NBR 106200	12019336	○

● Available from stock ○ On request: Tool is available, delivery at short notice

Simmerring Cassette Seal HS (high speed)

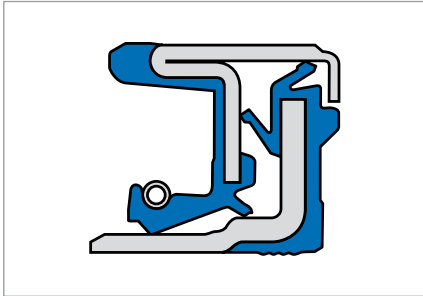

Fig.1 Simmerring Cassette Seal HS

Product description

- Design: special types, on enquiry
- Outer casing: elastomer/sheet metal
- Spring-loaded sealing lip
- Additional dust lips
- High resistance to dirt ingress.

Product advantages

- Strategic principle: elastomer/metal sheets on the inside diameter and special design
- Extremely useful for applications with high r.p.m.
- Elastomer surface guarantees static seal at inside diameter
- Metal surface guarantees higher thermal conduction and better heat distribution
- Fast and reliable replacement for applications in the spare parts sector
- Shaft surface treatment not necessary.

Application

These examples of use provide general information on the primary applications for the Simmerring Cassette Seal HS. The Simmerring Cassette Seal HS is used in pinions, in both the industrial and commercial vehicle sectors:

- Agricultural machinery (tractors)
- Commercial vehicles (small trucks, small special vehicles)
- Pinions
- Differential
- Drive engineering.

Material

For slip ring:

Fluoro elastomer

Code	75 FKM 585
Colour	Dark brown

For Simmerring:

Acrylonitrile-butadiene rubber

Code	75 NBR 106200
Colour	Black

Acrylate rubber

Code	68 ACM
Colour	Black

Metal insert	Unalloyed steel DIN 1624 – EN 10139
Spring	Spring steel 17223

Operating conditions

Materials combination	For Simmerring 75 FKM 585	For slip ring 75 NBR 106200	For slip ring 68 ACM
T	<120 °C	<80 °C	<100 °C
v	to 12 m/s	–	–
p	max. 0,03 MPa/0,3 bar	–	–

For material definitions, it must be taken into account that it is possible that not all extreme conditions will occur simultaneously.

Fitting & installation

Shaft

Tolerance	ISO h8
Runout	IT 8
Roughness	$R_z = 10 \dots 16 \mu\text{m}$

Housing bore

Tolerance	ISO h8
Roughness	$R_z = 10 \dots 16 \mu\text{m}$

Careful fitting according to DIN 3760 is a prerequisite for the correct function of the seal → Technical Manual.

Further information on enquiry.

Range of dimensions for shafts- $\varnothing D_1$

Further information on enquiry.

Simmerring Combi Seal

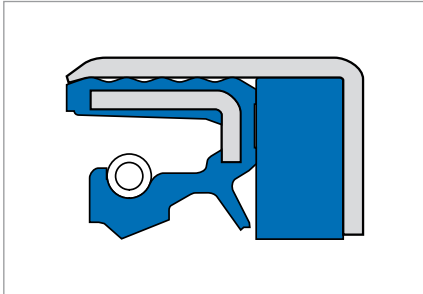

Fig. 1 Simmerring Combi Seal

Product description

- Design: special types, on enquiry
- Combination of a Simmerring and an additional seal against dirt from the outside in one housing
- Spring-loaded sealing lip
- Additional dust lip
- Primarily for usage in all applications with high level of soiling, e.g., in axles for off-road vehicles
- Use preferably instead of the Simmerring Cassette Seal in case of superimposed rotational and translation movements.

Product advantages

- Long service life
- High resistance to dirt ingress due to the optimal positioning of sealing lip and dust lip.

Performance in relation to dirt from the outside

- High resistance to dirt from the outside. Suitable for protection against dry dirt.

Application

- Agricultural machinery
- Drives for agricultural vehicles and in general industry
- Drives for rotating, sometimes running shafts in dry application areas.

Material

Acrylonitrile-butadiene rubber

Code	75 NBR 106200
Colour	Black
Hardness	75 Shore A

Fluoro elastomer

Code	75 FKM 595
Colour	Red brown
Hardness	75 Shore A

Metal insert	Unalloyed steel DIN 1624 – EN10139
Spring	Spring steel 17223
Dirt wiper	Polyurethane (AU)

Operating conditions

Materials combination	NBR/AU
T	to +80 °C
v	to 5 m/s
P	max. 0,05 MPa/0,5 bar

Fitting & installation

Shaft

Tolerance	ISO h 11
Runout	IT 8
Roughness	$R_a = 0,2 \dots 0,8 \mu\text{m}$
	$R_z = 1,0 \dots 5,0 \mu\text{m}$
	$R_{\text{max}} = \leq 6,3 \mu\text{m}$
Hardness	45 ... 60 HRC
Finish	No lead; preferably plunge ground

Housing bore

Tolerance	ISO H8
Roughness	$R_z = 10 \dots 16 \mu\text{m}$

Careful fitting according to DIN 3760 is a prerequisite for the correct function of the seal → Technical Manual.

Further information on enquiry.

Range of dimensions for shafts $\varnothing D_1$

Simmerring Combi Seal	30 ... 220 mm
-----------------------	---------------

Article list

D ₁	D ₂	b	Material	Article No.	
30	44	11	72 NBR 902	12001879	○
35	49	11	72 NBR 902	12001880	○
35	50	10	72 NBR 902	12001881	○
35	52	10	72 NBR 902	12011716	○
35	52	16	72 NBR 902	12001882	○
35	62	12	72 NBR 902	12012786	○
35	72	12	72 NBR 902	12001883	○
40	55	10	72 NBR 902	12001886	○
40	58	10	72 NBR 902	12001887	○
40	62	10	72 NBR 902	12011715	○
42	62	14	72 NBR 902	12001889	○
45	62	11	72 NBR 902	12012296	○
45	65	12	72 NBR 902	12011969	○
48	65	11	72 NBR 902	12011991	○
48	74	13	72 NBR 902	12001898	○
50	75	12	72 NBR 902	12012503	○
55	72	12	75 NBR 904	12011794	○
55	80	11	72 NBR 902	12013176	○
57	72	11	72 NBR 902	12013172	○
60	80	12	72 NBR 902	12012930	○
62	80	11	72 NBR 902	12013173	○
65	92	14	72 NBR 902	12001903	○
65	98	15	72 NBR 902	12011697	○
68	85	12	72 NBR 902	12013339	○
74	91	12	72 NBR 902	12013338	○
75	102	14	72 NBR 902	12001907	○
80	110	16	72 NBR 902	12001908	○
85	110	16	72 NBR 902	12001909	○
90	120	13	72 NBR 902	12001910	○
90	122	17	72 NBR 902	12001911	○
95	120	13	72 NBR 902	12012399	○
100	130	16	72 NBR 902	12001912	○
105	125	16	72 NBR 902	12001913	○
105	130	12	72 NBR 902	12011717	○
105	140	16	72 NBR 902	12001914	○
110	130	12	72 NBR 902	12013174	○
110	130	16	72 NBR 902	12015364	○
110	150	16	72 NBR 902	12001916	○
112	140	13,2	72 NBR 902	12001917	○
120	150	15	72 NBR 902	12001918	○
130	160	16	72 NBR 902	12001919	○
130	170	16	72 NBR 902	12001920	○
136	165,5	16	68 ACM 362	12013067	○
145	170	16	72 NBR 902	12001922	○
150	170	16	72 NBR 902	12001923	○
155	176	16	72 NBR 902	12001924	○
165	190	17	72 NBR 902	12001925	○
170	190	15	72 NBR 902	12013074	○

● Available from stock ○ On request: Tool is available, delivery at short notice

D ₁	D ₂	b	Material	Article No.	
170	205	17	72 NBR 902	12012053	<input type="radio"/>
180	205	17	72 NBR 902	12011690	<input type="radio"/>
190	215	17	72 NBR 902	12015590	<input type="radio"/>
190	220	20	72 NBR 902	12001926	<input type="radio"/>
220	250	20	72 NBR 902	12001928	<input type="radio"/>

● Available from stock ○ On request: Tool is available, delivery at short notice

Simmerring Combi Seal SF5

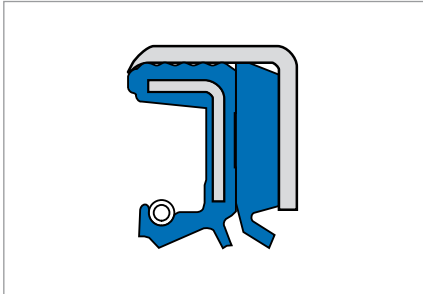

Fig. 1 Simmerring Combi Seal SF5

Product description

- Design: special types, on enquiry
- Combination of a Simmerring and an additional seal against dirt from the outside in one housing
- Spring-loaded sealing lip
- Additional dust lip
- Primarily for usage in all applications with high level of soiling, e.g., in axles for off-road vehicles
- Use preferably instead of the Simmerring Cassette Seal in case of superimposed rotational and translation movements.

Product advantages

- Long service life
- High resistance to dirt ingress due to the optimal positioning of sealing lip and dust lip.

Performance in Relation to Dirt from the Outside

- High resistance to dirt from the outside. Suitable for protection against sludge.

Application

- Agricultural machinery
- Drives for agricultural vehicles and in general industry
- Drives for rotating, sometimes running shafts in dry application areas.

Material

Acrylonitrile-butadiene rubber

Code	75 NBR 106200
Colour	Black
Hardness	75 Shore A

Fluoro elastomer

Code	75 FKM 595
Colour	Red brown
Hardness	75 Shore A

Metal insert	Unalloyed steel DIN 1624 – EN10139
Spring	Spring steel 17223
Dirt wiper	Polyurethane (AU)

Operating conditions

Materials combination	NBR/AU	FKM/AU
T	to +80 °C	to +100 °C
v	to 4 m/s	to 6 m/s
p	max. 0,05 MPa/0,5 bar	max. 0,05 MPa/0,5 bar

For material definitions, it must be taken into account that it is possible that not all extreme conditions will occur simultaneously.

Fitting & installation

Shaft

Tolerance	ISO h 11
Runout	IT 8
Roughness	$R_a = 0,2 \dots 0,8 \mu\text{m}$
	$R_z = 1,0 \dots 5,0 \mu\text{m}$
	$R_{\text{max}} = \leq 6,3 \mu\text{m}$
Hardness	45 ... 60 HRC
Finish	No lead; preferably plunge ground

Housing bore

Tolerance	ISO H8
Roughness	$R_z = 10 \dots 16 \mu\text{m}$

Careful fitting according to DIN 3760 is a prerequisite for the correct function of the seal → Technical Manual.

The use of sealing material on the outer diameter is recommended for the fitting.

Further information on enquiry.

Range of dimensions for shafts- $\varnothing D_1$

Simmerring Combi Seal SF5	35 ... 120 mm
---------------------------	---------------

Article list

D ₁	D ₂	b	Material	Article No.	
35	50	13	72 NBR 902	12013947	<input type="radio"/>
40	68	14	72 NBR 902	12013319	<input type="radio"/>
45	62	11,2	72 NBR 902	12016814	<input type="radio"/>

● Available from stock ○ On request: Tool is available, delivery at short notice

Simmerring Combi Seal SF6

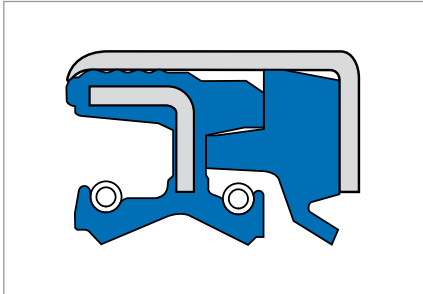

Fig. 1 Simmerring Combi Seal SF6

Product description

- Design: special types, on enquiry
- Combination of a Simmerring and an additional seal against dirt from the outside in one housing
- Spring-loaded sealing lip
- Additional dust lip
- Primarily for usage in all applications with high level of soiling, e.g., in axles for off-road vehicles
- Use preferably instead of the Simmerring Cassette Seal in case of superimposed rotational and translation movements.

Product advantages

- Long service life
- High resistance to dirt ingress due to the optimal positioning of sealing lip and dust lip.

Performance in relation to dirt from the outside

- High resistance to dirt from the outside. Suitable for protection against sludge.

Application

- Agricultural machinery
- Drives for agricultural vehicles and in general industry
- For rotating, sometimes running shafts in wet /moist application areas.

Material

Acrylonitrile-butadiene rubber

Code	75 NBR 106200
Colour	Black
Hardness	75 Shore A

Fluoro elastomer

Code	75 FKM 595
Colour	Red brown
Hardness	75 Shore A

Metal insert	Unalloyed steel DIN 1624 – EN10139
Spring	Spring steel 17223
Dirt wiper	Polyurethane (AU)

Operating conditions

Materials combination	NBR/AU	FKM/AU
T	to +80 °C	to +100 °C
v	to 4 m/s	to 6 m/s
p	max. 0,05 MPa/0,5 bar	max. 0,05 MPa/0,5 bar

Fitting & installation

Shaft

Tolerance	ISO h 11
Runout	IT 8
Roughness	$R_a = 0,2 \dots 0,8 \mu\text{m}$
	$R_z = 1,0 \dots 5,0 \mu\text{m}$
	$R_{\text{max}} = \leq 6,3 \mu\text{m}$
Hardness	45 ... 60 HRC
Finish	No lead; preferably plunge ground

Housing bore

Tolerance	ISO H8
Roughness	$R_z = 10 \dots 16 \mu\text{m}$

Careful fitting according to DIN 3760 is a prerequisite for the correct function of the seal → Technical Manual.

The use of sealing material on the outer diameter is recommended for the fitting.

Further information on enquiry.

Range of dimensions for shafts-Ø D₁

Simmerring Combi Seal SF6	30 ... 130 mm
---------------------------	---------------

Article list

D ₁	D ₂	b	Material	Article No.	
30	44	14	72 NBR 902	12013519	○
35	52	16	72 NBR 902	12013466	○
35	60	18,5	72 NBR 902	12014167	○
40	55	15,5	72 NBR 902	12018848	○
40	60	18,5	72 NBR 902	12012107	○
40	65	18,5	72 NBR 902	12013226	○
42	62	21,5	72 NBR 902	12016507	○
45	65	18,5	72 NBR 902	12012377	○
47	65	16,5	72 NBR 902	12015734	○
48	65	16,5	75 FKM 595	12017310	○
48	74	18,5	72 NBR 902	12017349	○
50	72	16,5	75 NBR 106200	12014048	○
55	82	16,5	75 NBR 106200	12014159	○
56	75	16,5	72 NBR 902	12012826	○
56	80	16	75 NBR 106200	12018868	○
58	80	16,5	72 NBR 902	12012468	○
58	82	16	75 FKM 595	12017237	○
65	92	18	72 NBR 902	12013465	○
70	90	16,5	75 NBR 106200	12013784	○
70	95	15	72 NBR 902	12012318	○
80	100	18	72 NBR 902	12014976	○
130	154	18	72 NBR 902	12015132	○

● Available from stock ○ On request: Tool is available, delivery at short notice

Simmerring Combi Seal SF8

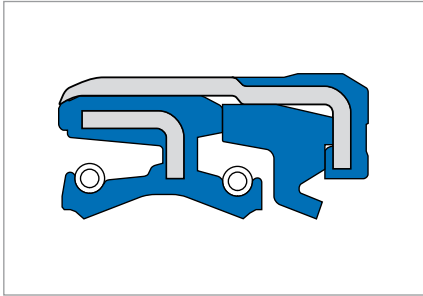

Fig. 1 Simmerring Combi Seal SF8

Product description

- Design: special types, on enquiry
- Static seal on the outer diameter (in comparison to the Combi SF6)
- Combination of a Simmerring and an additional seal against dirt from the outside in one housing
- Spring-loaded sealing lip
- Additional dust lip
- Primarily for usage in all applications with high level of soiling, e.g., in axles for off-road vehicles
- Use preferably instead of the Simmerring Cassette Seal in case of superimposed rotational and translation movements.

Product advantages

- Long service life
- High resistance to dirt ingress due to the optimal positioning of sealing lip and dust lip.

Performance in relation to dirt from the outside

- High resistance to dirt from the outside. Suitable for protection against sludge.

Application

- Agricultural machinery
- Transmissions drives for agricultural vehicles and in general industry.
- For rotating, sometimes running shafts in wet /moist application areas.

Material

Acrylonitrile-butadiene rubber

Code	75 NBR 106200
Colour	Black
Hardness	75 Shore A

Fluoro elastomer

Code	75 FKM 595
Colour	Red brown
Hardness	75 Shore A

Metal insert	Unalloyed steel DIN 1624 – EN10139
Spring	Spring steel 17223
Dirt wiper	Polyurethane (AU)

Operating conditions

Materials combination	NBR/AU	FKM/AU
T	to +80 °C	to +100 °C
v	to 4 m/s	to 6 m/s
p	max. 0,05 MPa/0,5 bar	max. 0,05 MPa/0,5 bar

For material definitions, it must be taken into account that it is possible that not all extreme conditions will occur simultaneously.

Fitting & installation

Shaft

Tolerance	ISO h11
Runout	IT 8
Roughness	$R_a = 0,2 \dots 0,8 \mu\text{m}$
	$R_z = 1,0 \dots 5,0 \mu\text{m}$
	$R_{\text{max}} = \leq 6,3 \mu\text{m}$
Hardness	45 ... 60 HRC
Finish	No lead; preferably plunge ground

Housing bore

Tolerance	ISO H8
Roughness	$R_z = 10 \dots 16 \mu\text{m}$

Careful fitting according to DIN 3760 is a prerequisite for the correct function of the seal → Technical Manual.

Further information on enquiry.

Range of dimensions for shafts- $\varnothing D_1$

Simmerring Combi Seal SF8	37 ... 75 mm
---------------------------	--------------

Article list

D ₁	D ₂	b	Material	Article No.	
37	52	16	72 NBR 902	12014511	<input type="radio"/>
45	60	16	72 NBR 902	12014977	<input type="radio"/>
50	65	18	72 NBR 902	12018616	<input type="radio"/>
55	80	16	72 NBR 902	12013931	<input type="radio"/>
60	75	16	72 NBR 902	12013740	<input type="radio"/>
75	95	16,5	72 NBR 902	12014456	<input type="radio"/>

● Available from stock ○ On request: Tool is available, delivery at short notice

Simmerring Combi Seal SF19

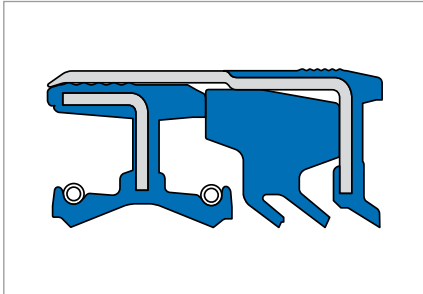

Fig. 1 Simmerring Combi Seal SF19

Product description

- Design: special types, on enquiry
- Combination of a Simmerring and an additional seal against dirt from the outside in one housing
- Spring-loaded sealing lip
- Additional dust lip for preventing the ingress of dirt and for protection under extreme operating conditions
- Primarily for usage in all applications with high level of soiling, e.g., in axles for off-road vehicles
- Use preferably instead of the Simmerring Cassette Seal in case of superimposed rotational and translation movements.

Product advantages

- Long service life
- High resistance to dirt ingress due to the optimal positioning of sealing lip and dust lip.

Performance in relation to dirt from the outside

- High resistance to dirt from the outside. Suitable for protection against sludge.

Application

- Agricultural machinery
- For extreme dirt ingress and critical applications
- Drives for agricultural vehicles and in general industry.

Material

Acrylonitrile-butadiene rubber

Code	75 NBR 106200
Colour	Black
Hardness	75 Shore A

Fluoro elastomer

Code	75 FKM 595
Colour	Red brown
Hardness	75 Shore A

Metal insert	Unalloyed steel DIN 1624 – EN10139
Spring	Spring steel 17223
Dirt wiper	Polyurethane (AU)

Operating conditions

Materials combination	NBR/AU	FKM/AU
T	to +80 °C	to +100 °C
v	to 4 m/s	to 6 m/s
p	max. 0,05 MPa/0,5 bar	max. 0,05 MPa/0,5 bar

For material definitions, it must be taken into account that it is possible that not all extreme conditions will occur simultaneously.

Fitting & installation

Shaft

Tolerance	ISO h11
Runout	IT 8
Roughness	$R_a = 0,2 \dots 0,8 \mu\text{m}$
	$R_z = 1,0 \dots 5,0 \mu\text{m}$
	$R_{\text{max}} = \leq 6,3 \mu\text{m}$
Hardness	45 ... 60 HRC
Finish	No lead; preferably plunge ground

Housing bore

Tolerance	ISO H8
Roughness	$R_z = 10 \dots 16 \mu\text{m}$

Careful fitting according to DIN 3760 is a prerequisite for the correct function of the seal → Technical Manual.

Further information on enquiry.

Range of dimensions for shafts $\varnothing D_1$

Simmerring Combi Seal SF19	37 ... 75 mm
----------------------------	--------------

Article list

D ₁	D ₂	b	Material	Article No.	
30	44	17	75 NBR 106200	12020067	<input type="radio"/>
40	65	27,5	75 NBR 106200	12020191	<input type="radio"/>
42	62	23	75 NBR 106200	12020023	<input type="radio"/>
45	75	27,5	75 NBR 106200	12020036	<input type="radio"/>
47	65	19	75 NBR 106200	12020133	<input type="radio"/>
52	72	16,5	75 NBR 106200	12020074	<input type="radio"/>

● Available from stock ○ On request: Tool is available, delivery at short notice